

Optical and Infrared Detectors for Astronomy

Basic Principles to State-of-the-art

James W. Beletic

NATO/ASI and Euro Summer School

Optics in Astrophysics

September 16-27, 2002

Goals of the Detector Course

The student should gain an understanding of:

3. The role detectors play in an astronomical observatory
Why detectors are the MOST important technology!
2. Fundamental detector physics
3. Standard detector architecture
4. What affects quantum efficiency and readout noise
5. The state-of-the-art today
6. Special applications / areas of research & development

Course Outline

- Lecture 1: Role of detectors in observatory
Detector physics
Standard architecture
- Lecture 2: Quantum efficiency
Readout noise
Detector imperfections
- Lecture 3: Manufacturers
Bigger devices / Mosaics
Electronics
Special applications
Optical CMOS and CMOS + CCD

Course Outline

Lecture 1: Role of detectors in observatory
 Detector physics
 Standard architecture

Optical and Infrared Astronomy

(0.3 to 25 μ m)

Two basic parts

Telescope to collect and focus light

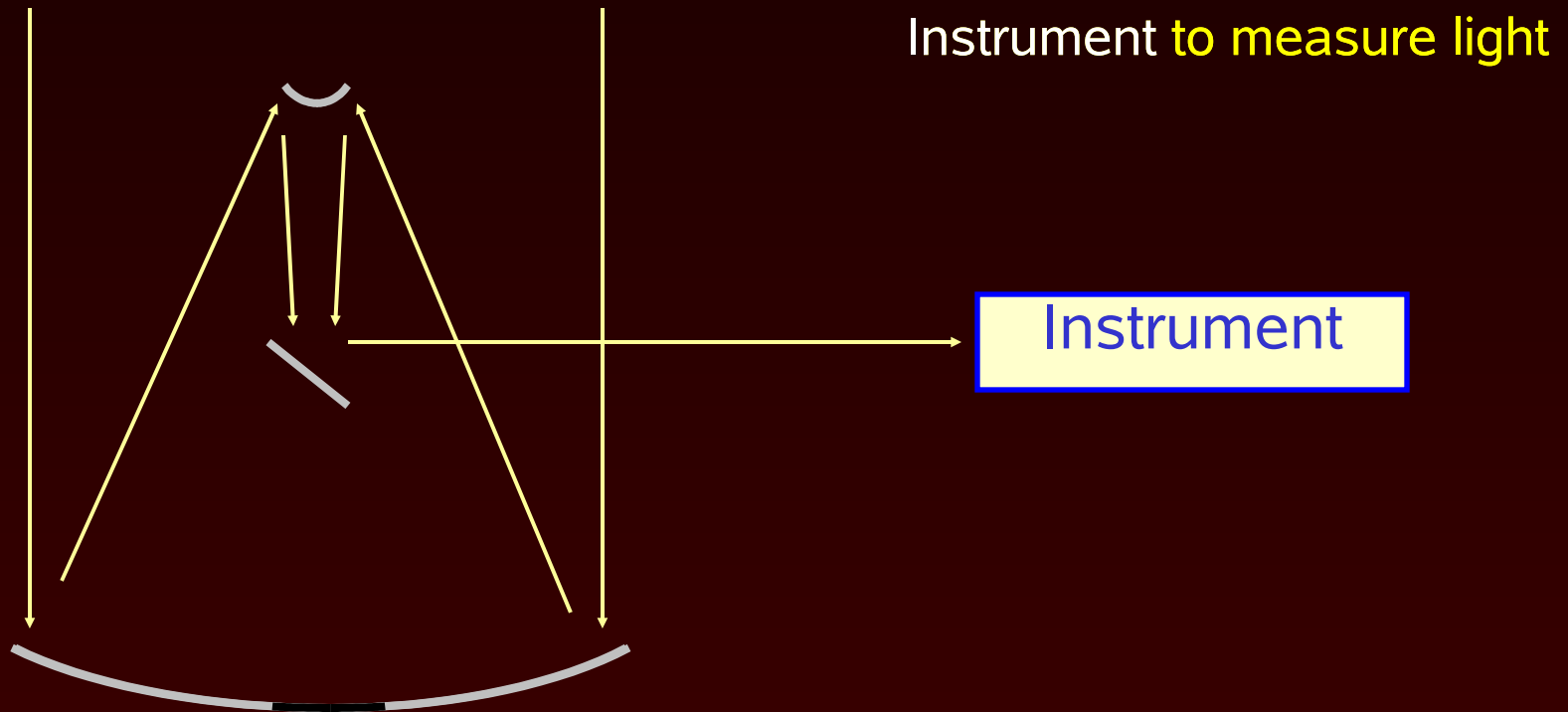

Optical and Infrared Astronomy

(0.3 to 25 μ m)

Okay, maybe a bit more complicated – 4 basic parts

Telescope to collect and focus light

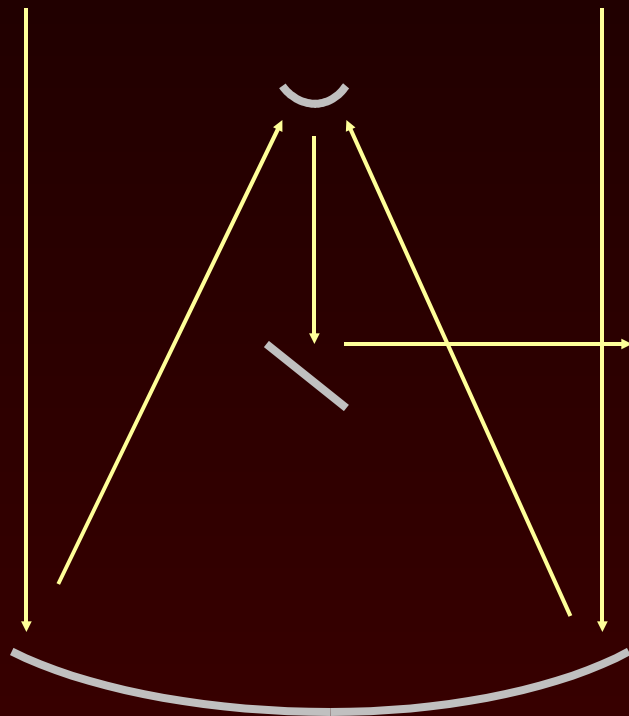

Adaptive
Optics

Instrument to
measure light

Optics

Detector



Instrument goal is to measure a 3-D data cube

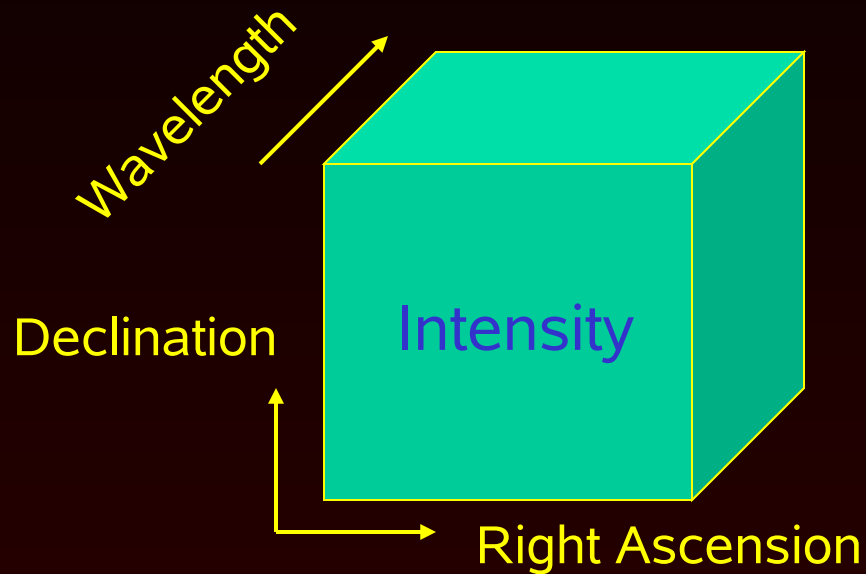

But detectors are 2-dimensional !

- Our detectors are **BLACK & WHITE**
- Can not measure color, only intensity

So the optics of the instrument are used to map a portion of the 3-D data cube on to the 2-D detector

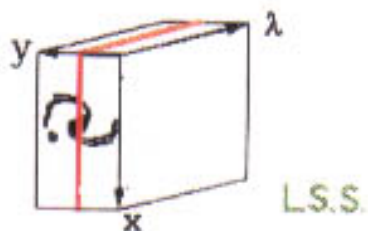
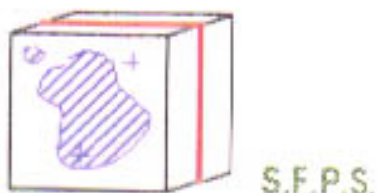
SOURCE**SPECTROGRAPHIC
MODES****VLI
INSTRUMENTS**Extended
ContinuumISAAC
FORS 1/2
CONICA
VISIRExtended
Emission

CONICA

Single Point
ContinuumLIVES
(CRIRES)Diluted-Point
ContinuumFORS 1/2
(NIRMOS/WFIS)
FUEGOSSingle Small
ContinuumFUEGOS
(SINFONI)

Where detectors are used in an observatory

Scientific:	Imaging Spectroscopy
Technical:	Acquisition / guiding Active optics Adaptive optics Interferometry (fringe & tip/tilt tracking) Site monitoring (seeing, clouds, LGS)
General:	Surveillance Safety

Detector zoology

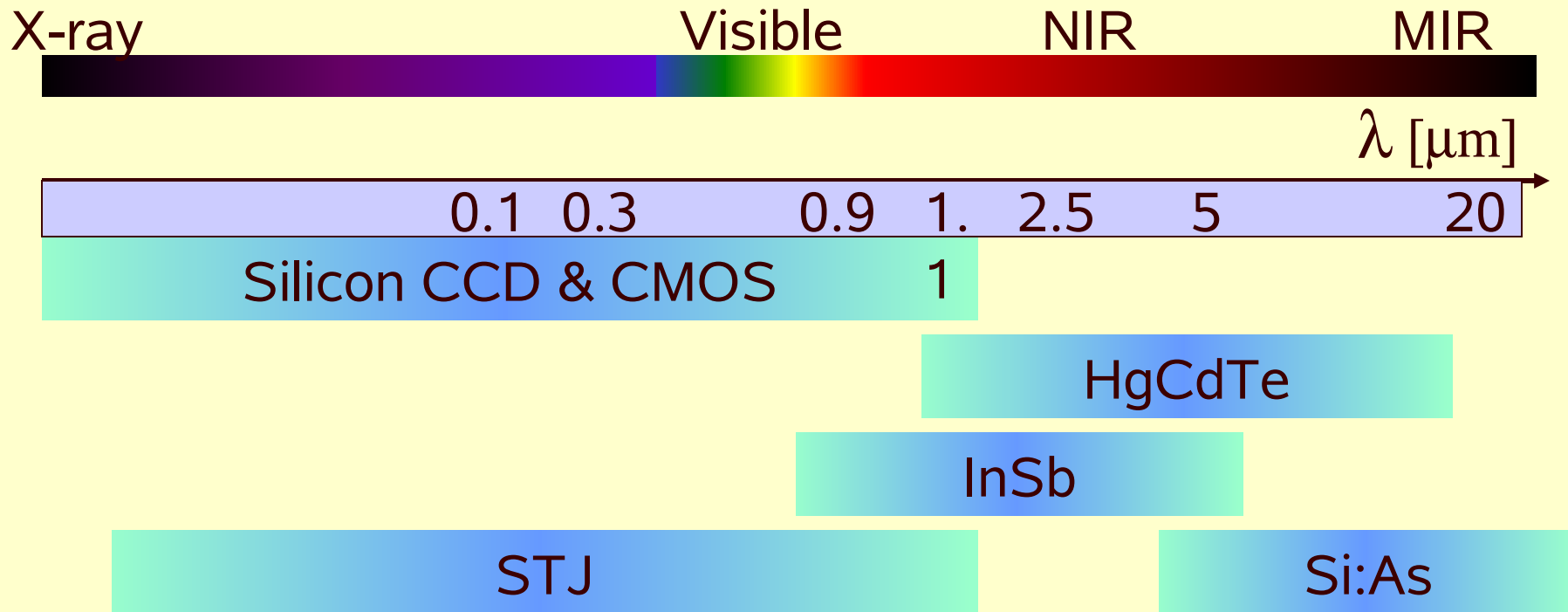

In this course, we concentrate on **2-D focal plane arrays**.

- Optical – silicon-based (CCD, CMOS)
- Infrared – IR material plus silicon CMOS multiplexer

Will not address: APD (avalanche photodiodes)

STJs (superconducting tunneling junctions)

The Ideal Detector

- Detect 100% of photons
 - Each photon detected as a delta function
 - Large number of pixels
 - Time tag for each photon
 - Measure photon wavelength
 - Measure photon polarization
- ✓ Up to 99% quantum efficiency
 - ✓ One electron for each photon
 - ✓ over 355 million pixels
 - ☒ No - framing detectors
 - ☒ No – defined by filter
 - ☒ No – defined by filter

Plus READOUT NOISE and other “features”

5 basic steps of optical/IR photon detection

1. Get light into the detector

Anti-reflection coatings

2. Charge generation

Popular materials: Silicon, HgCdTe, InSb

3. Charge collection

Electrical fields within the material collect photoelectrons into pixels.

4. Charge transfer

If infrared, no charge transfer required.

For CCD, move photoelectrons to the edge where amplifiers are located.

5. Charge amplification & digitization

Amplification process is noisy. In general CCDs have lowest noise, CMOS and IR detectors have higher noise.

Quantum
Efficiency

Point
Spread
Function

Sensitivity

Take notice

- Optical and IR focal plane arrays are similar in many ways
 - I will combine information about optical and IR detectors as much as possible.
- But optical and IR detectors are different in some important ways
 - I will try to be careful to differentiate when necessary.
- Please ask if you are ever confused whether the subject is optical and/or IR detectors.

Step 1: Get light into the detector

Anti-reflection coatings

- AR coatings will be discussed in lecture 2 when quantum efficiency is presented.

Step 2: Charge Generation

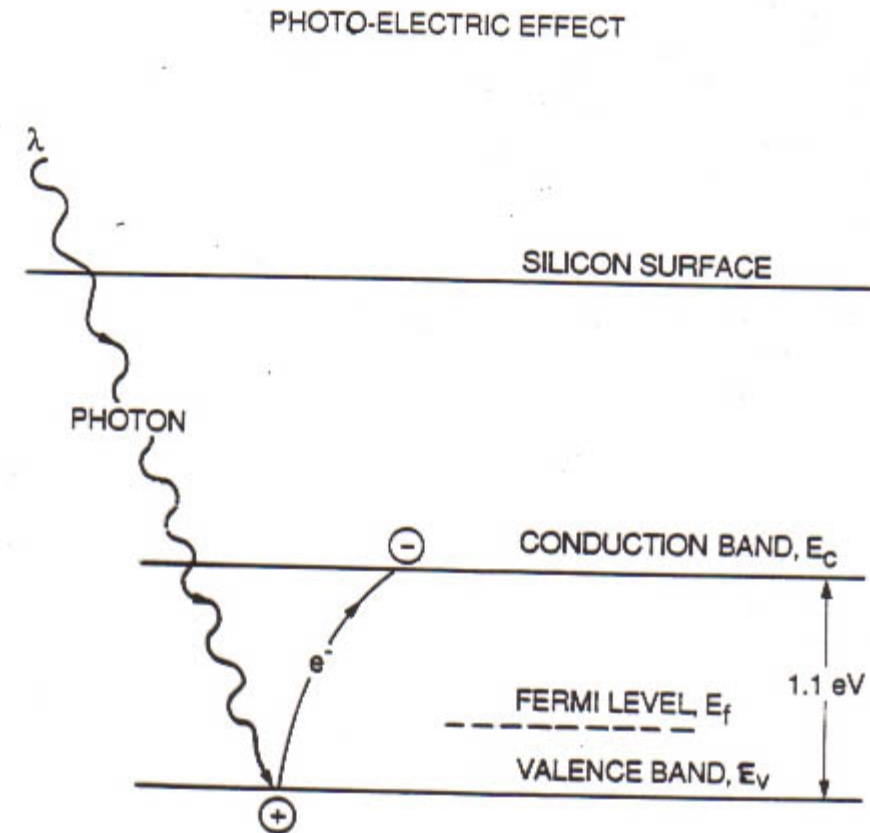

$$e^- = \frac{\text{ENERGY OF PHOTON (eV)}}{3.65 \text{ eV/e}^-}$$

$$\lambda (\text{\AA}) = \frac{12390}{\text{ENERGY OF PHOTON (eV)}}$$

Silicon CCD
Similar physics for
IR materials

Silicon Lattice

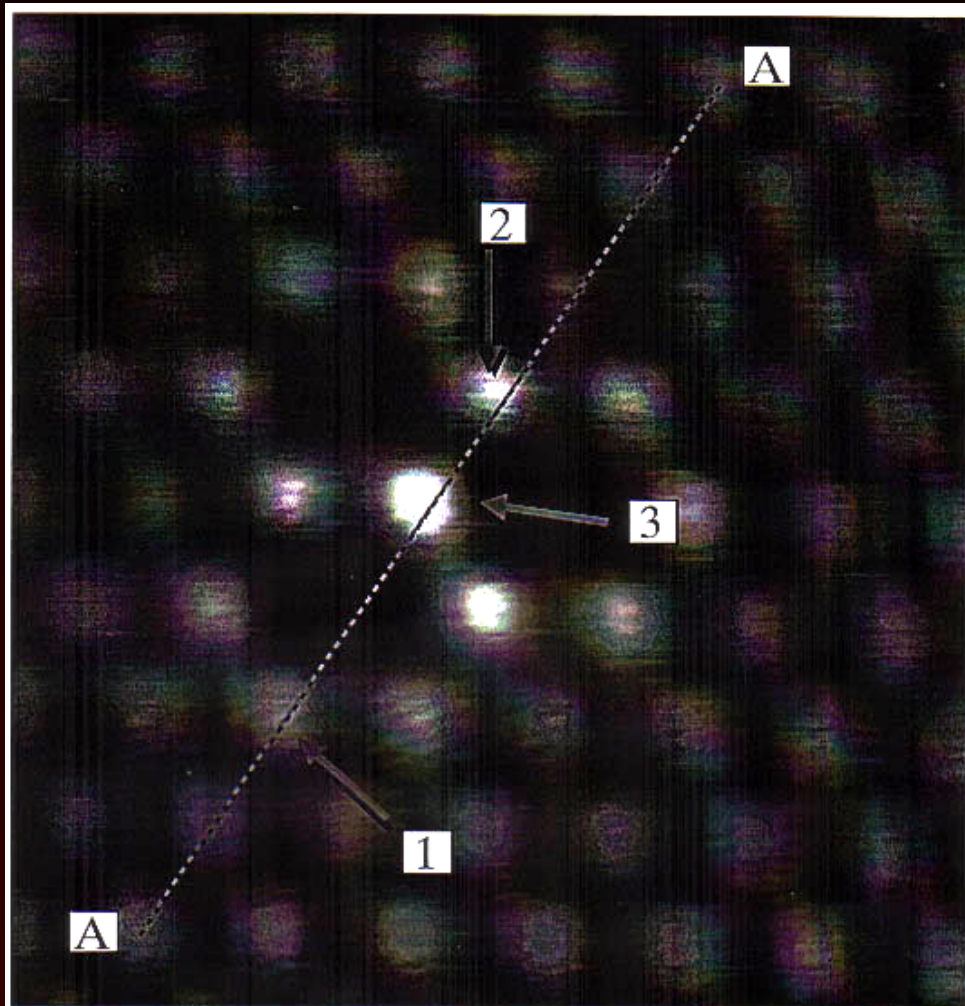

Silicon
Lattice constant
0.543 nm

Figure 1d. Filled state image of Sn on Si(111) surface with $V_{\text{tip}} = 0.5$ V and $I = 500$ pA. It shows change of the apparent height of Sn atoms with varying neighboring defects of type A.

Step 2: Charge Generation

Photon Detection

For an electron to be excited from the conduction band to the valence band

$$h \nu = E_g$$

h = Planck constant (6.6×10^{-34} Joule•sec)
 ν = frequency of light (cycles/sec) = c / λ

E_g = energy gap of material (electron-volts)

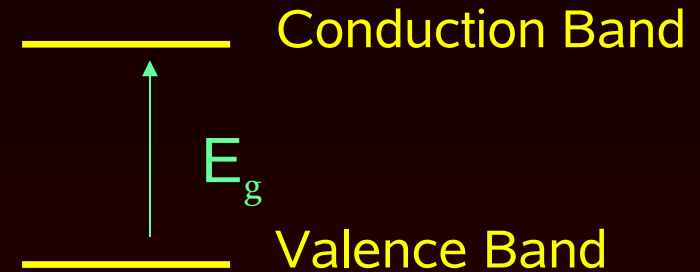

$$\lambda_c = 1.238 / E_g \text{ (eV)}$$

Material Name	Symbol	E_g (eV)	λ_c (μ m)
Silicon	Si	1.12	1.1
Mer-Cad-Tel	HgCdTe	1.00 – 0.09	1.24 – 14
Indium Antimonide	InSb	0.23	5.9
Arsenic doped Silicon	Si:As	0.05	24

Tunable Bandgap

A great property of Mer-Cad-Tel



Modify ratio of Mercury and Cadmium
to “tune” the bandgap energy

x	E_g (eV)	λ_c (μm)
0.196	.09	14
0.21	.12	10
0.295	.25	5
0.395	.41	3
0.55	.73	1.7
0.7	1.0	1.24

Step 2: Charge Generation

Photon Detection

For an electron to be excited from the conduction band to the valence band

$$h \nu \geq E_g$$

h = Planck constant (6.6×10^{-34} Joule•sec)
 ν = frequency of light (cycles/sec) = c / λ

E_g = energy gap of material (electron-volts)

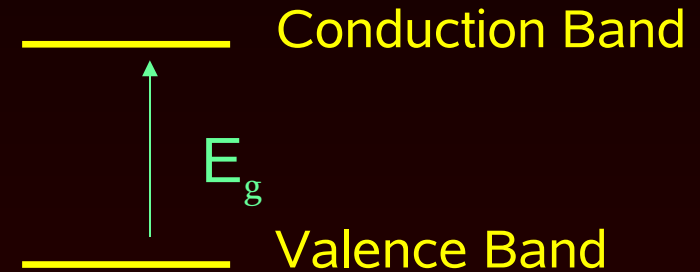

$$\lambda_c = 1.238 / E_g \text{ (eV)}$$

Material Name	Symbol	E_g (eV)	λ_c (μ m)	Operating Temp. (K)
Silicon	Si	1.12	1.1	163 - 300
Mer-Cad-Tel	HgCdTe	1.00 – 0.09	1.24 – 14	20 - 80
Indium Antimonide	InSb	0.23	5.9	30
Arsenic doped Silicon	Si:As	0.05	24	4

How small is an electron-volt (eV) ?

$$1 \text{ eV} = 1.6 \cdot 10^{-19} \text{ J}$$

$$1 \text{ J} = \text{N} \cdot \text{m} = \text{kg} \cdot \text{m} \cdot \text{sec}^{-2} \cdot \text{m}$$

$$1 \text{ kg raised 1 meter} = 9.8 \text{ J} = 6.1 \cdot 10^{19} \text{ eV}$$

How small is an electron-volt (eV) ?

DEIMOS example

DEIMOS – Deep Extragalactic Imager & Multi-Object Spectrograph

- 8K x 8K CCD array – 67 million pixels
- If 100 images / night, then ~13.5 Gbyte/night
- If used 1/3 of the year & all nights clear, 1.65 Tbyte/year
- If average pixel contains 5,000 photoelectrons
 - $4.1 \cdot 10^{15}$ photoelectrons / year
 - $4.6 \cdot 10^{15}$ eV / year

Single peanut M&M candy (2 g) falling 15 cm (6 inches) loses potential energy equal to $1.85 \cdot 10^{16}$ eV, same as total bandgap energy from four years of heavy DEIMOS use.

Step 3: Charge Collection

- Intensity image is generated by collecting photoelectrons generated in 3-D volume into 2-D array of pixels.
- Optical and IR focal plane arrays both collect charges via electric fields.
- In the z-direction, optical and IR use a p-n junction to “sweep” charge toward pixel collection nodes.

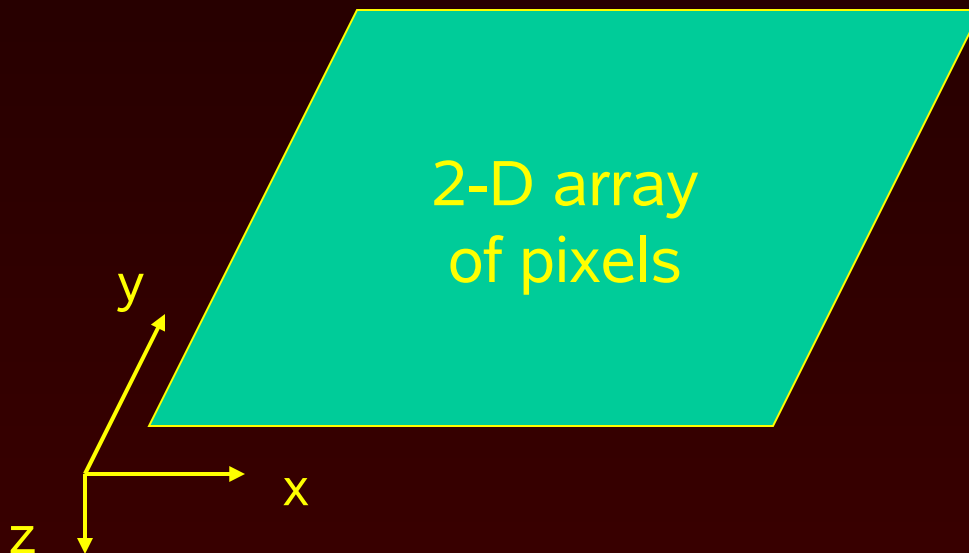

Photovoltaic Detector Potential Well

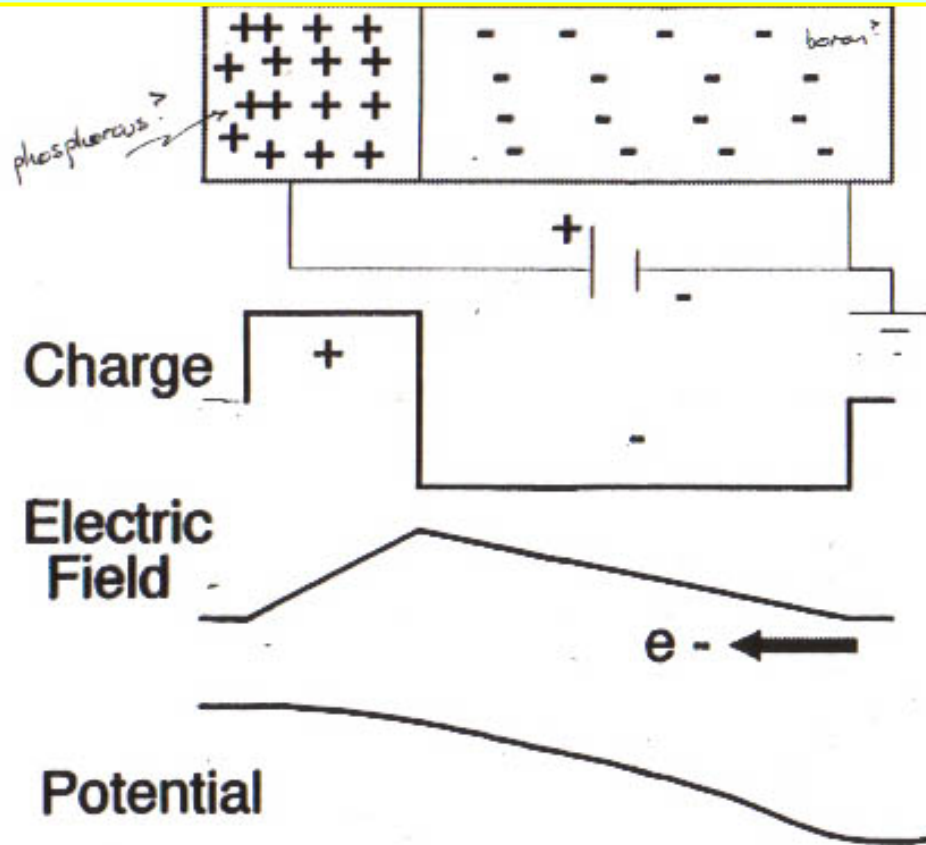

*reverse bias
the junction*

Note bene !

**Can collect either
electrons or holes**

Silicon CCD & HgCdTe and InSb are photovoltaic detectors. They use a pn junction to generate E-field in the z-direction of each pixel. This electric field separates the electron-hole pairs generated by a photon.

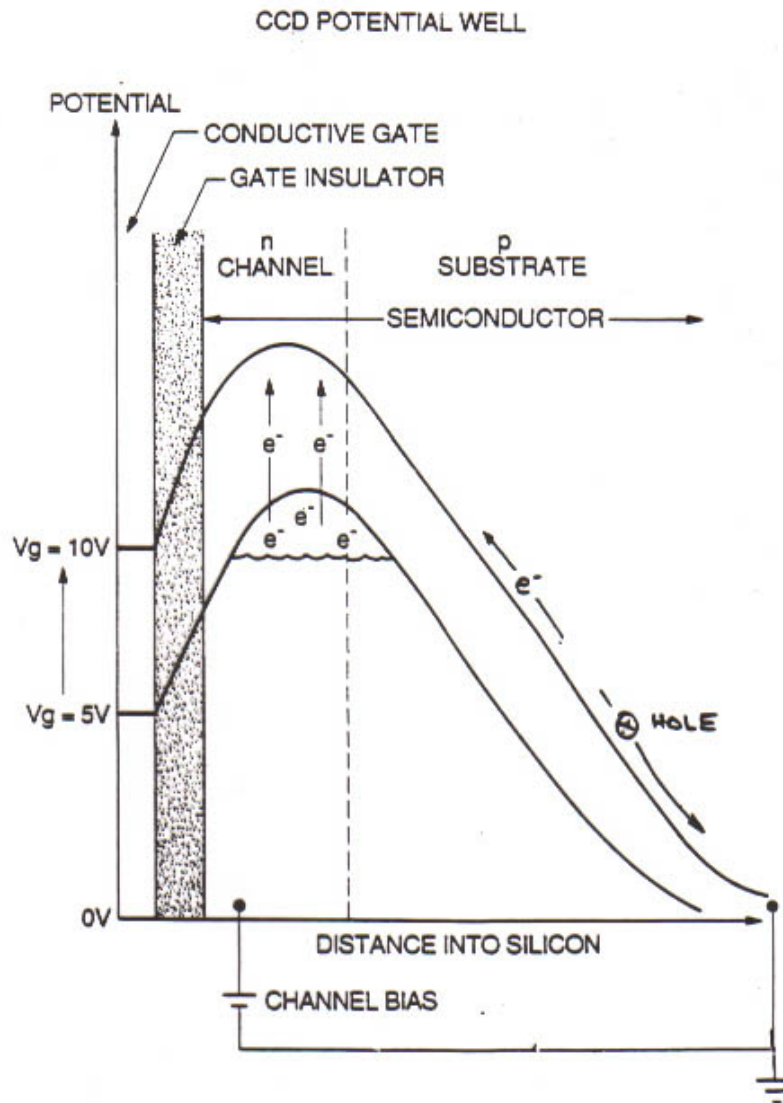

A BURIED CHANNEL CCD

n - phosphorous
p - boron

For silicon

n – region from phosphorous doping

p – region from boron doping

n-channel CCD
collects electrons

p-channel CCD
collect holes

Step 3: Charge Collection

- Optical and IR focal plane arrays are different for charge collection in the x and y dimensions.
- IR – collect charge at each pixel and have amplifiers and readout multiplexer
- CCD – collect charge in array of pixels. At end of frame, move charge to edge of array where one (or more) amplifier (s) read out the pixels.

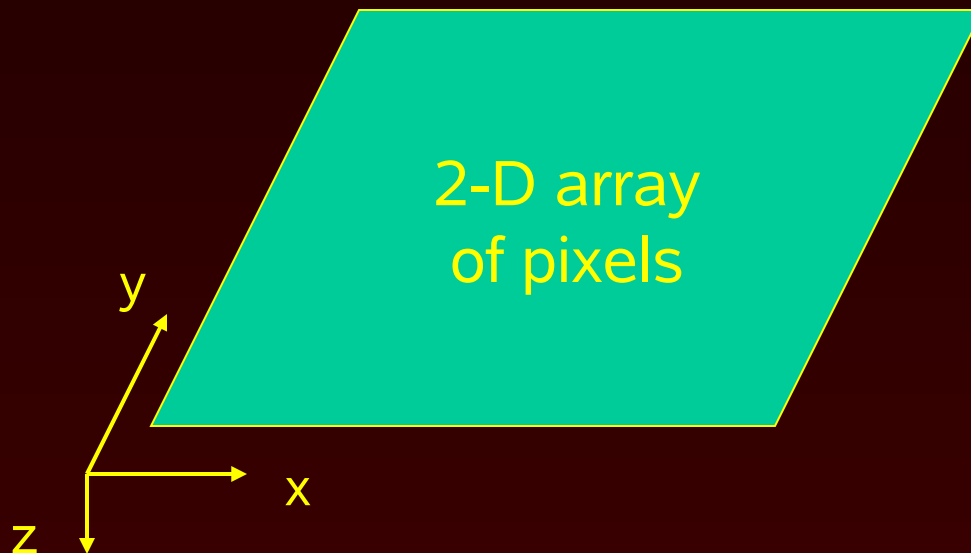

Infrared Pixel Geometry

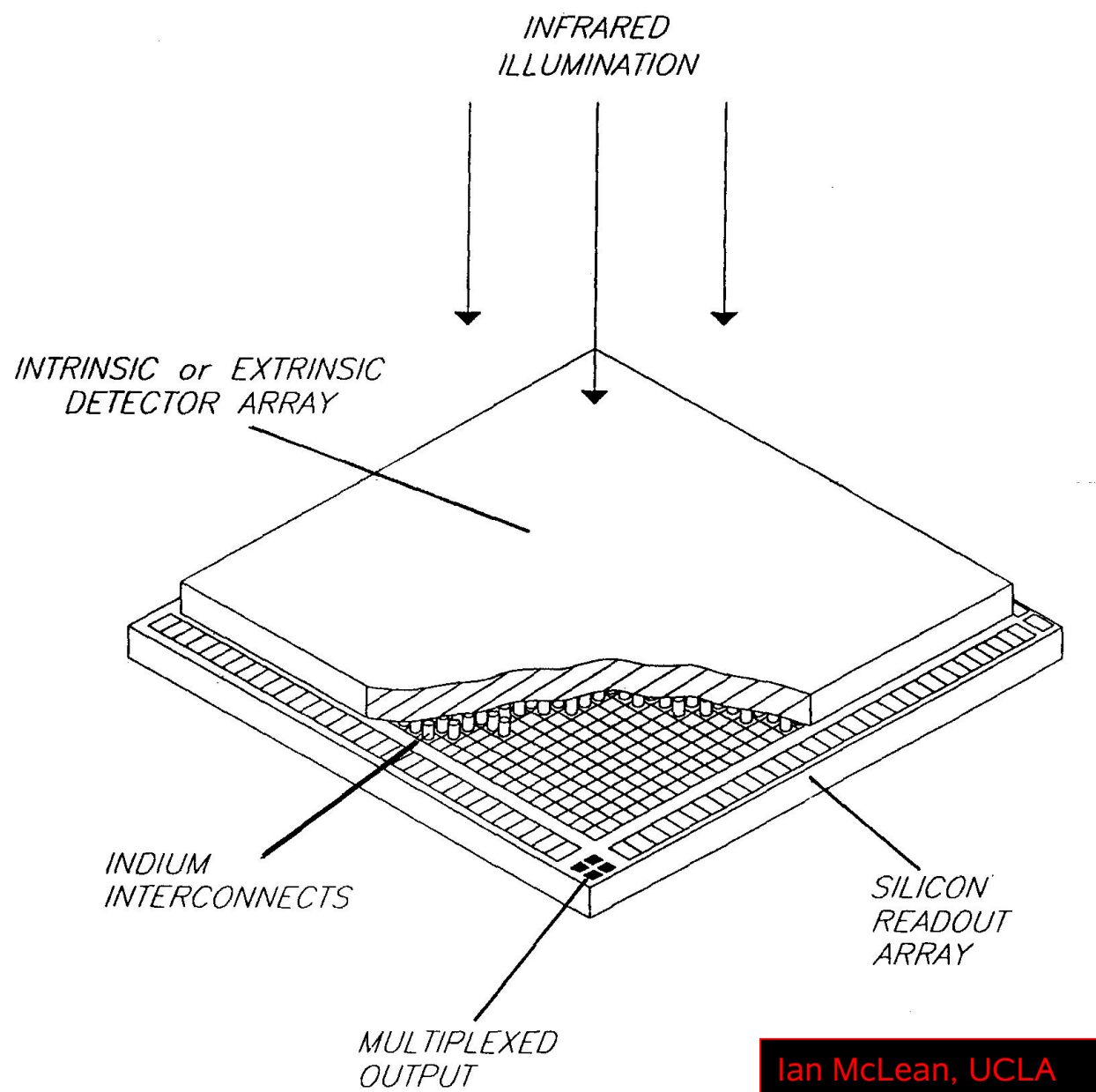

Infrared Detector Cross-section (InSb example)

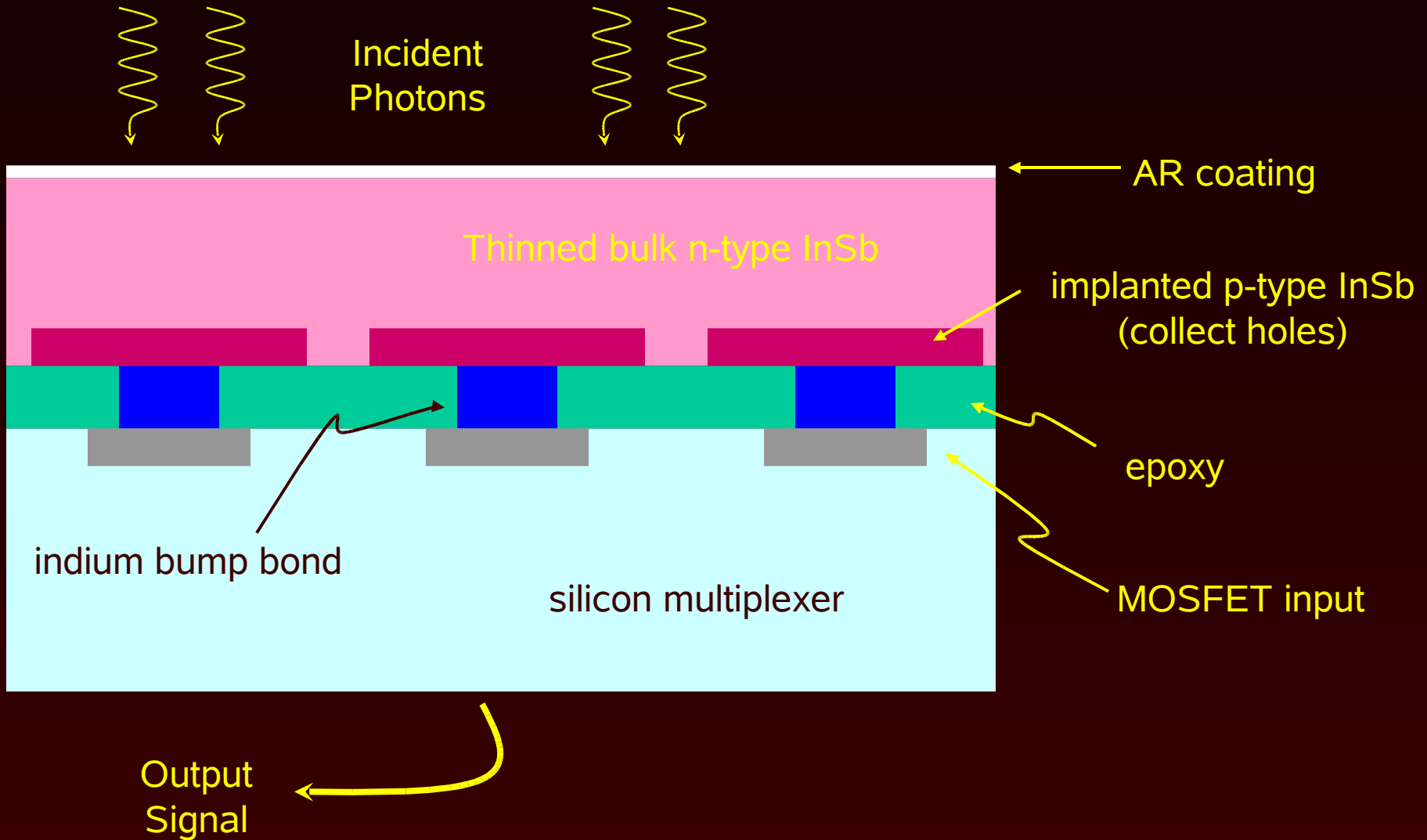

Infrared Detector Cross-section (new Rockwell HgCdTe design)

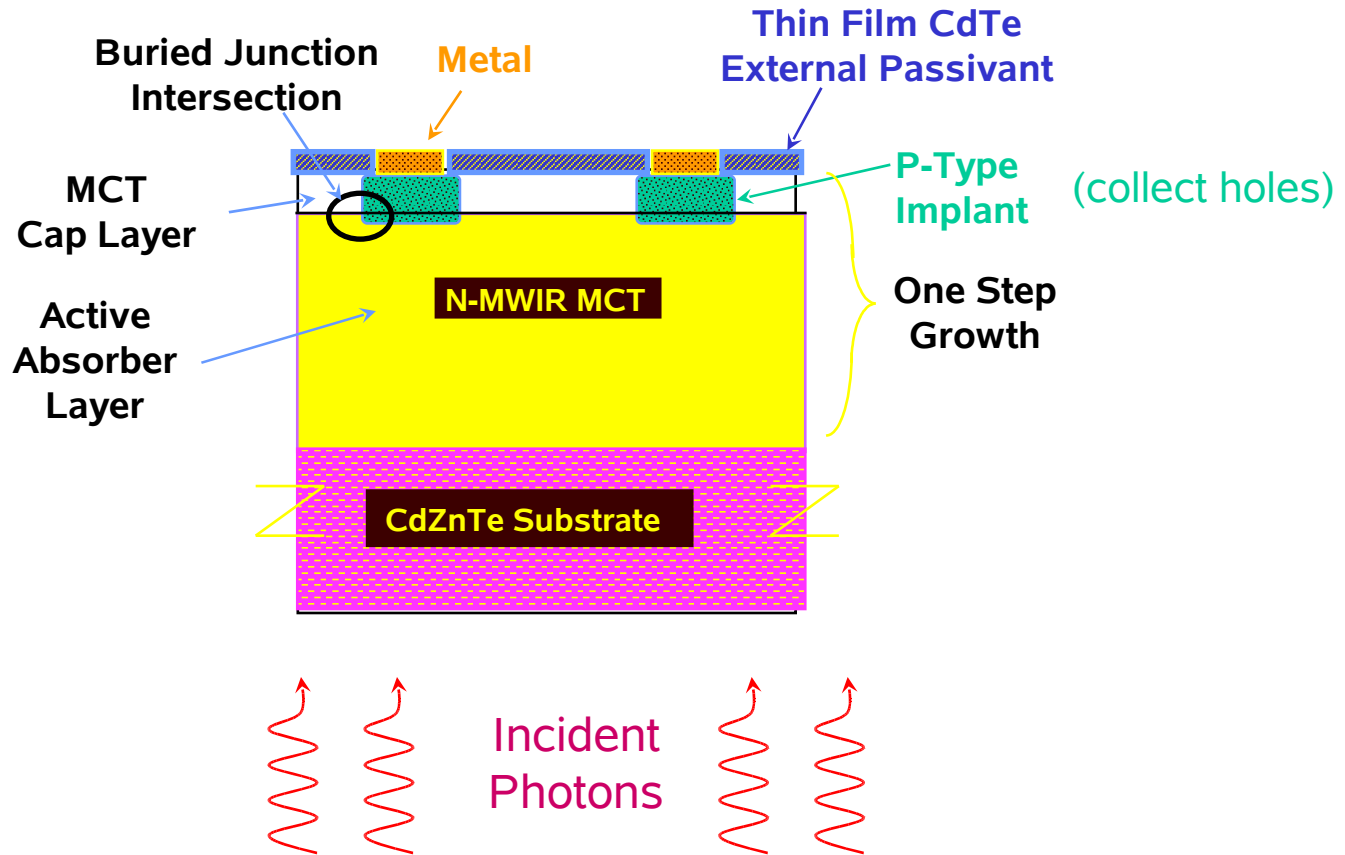

CCD Architecture

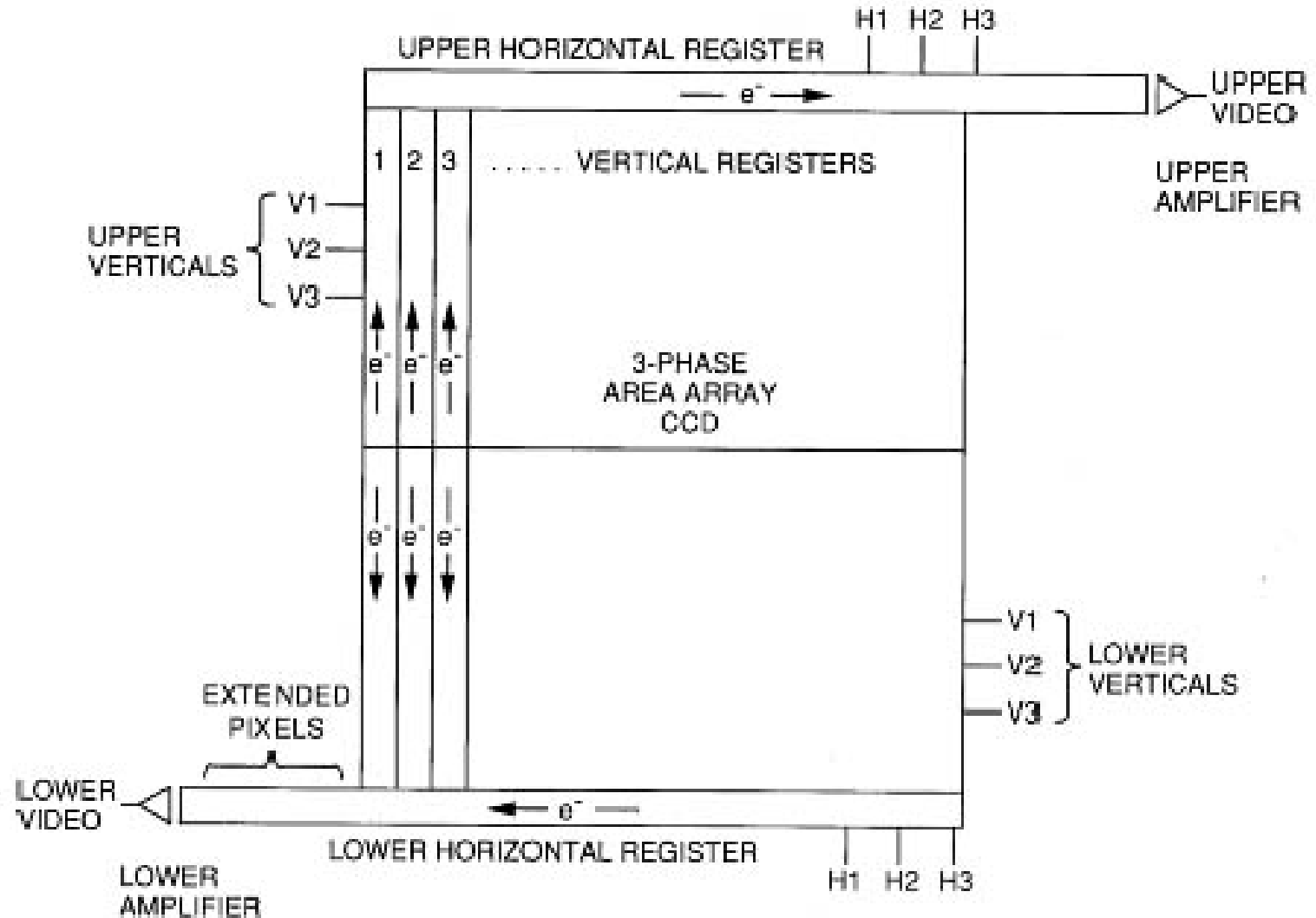

CCD Pixel Architecture – column boundaries

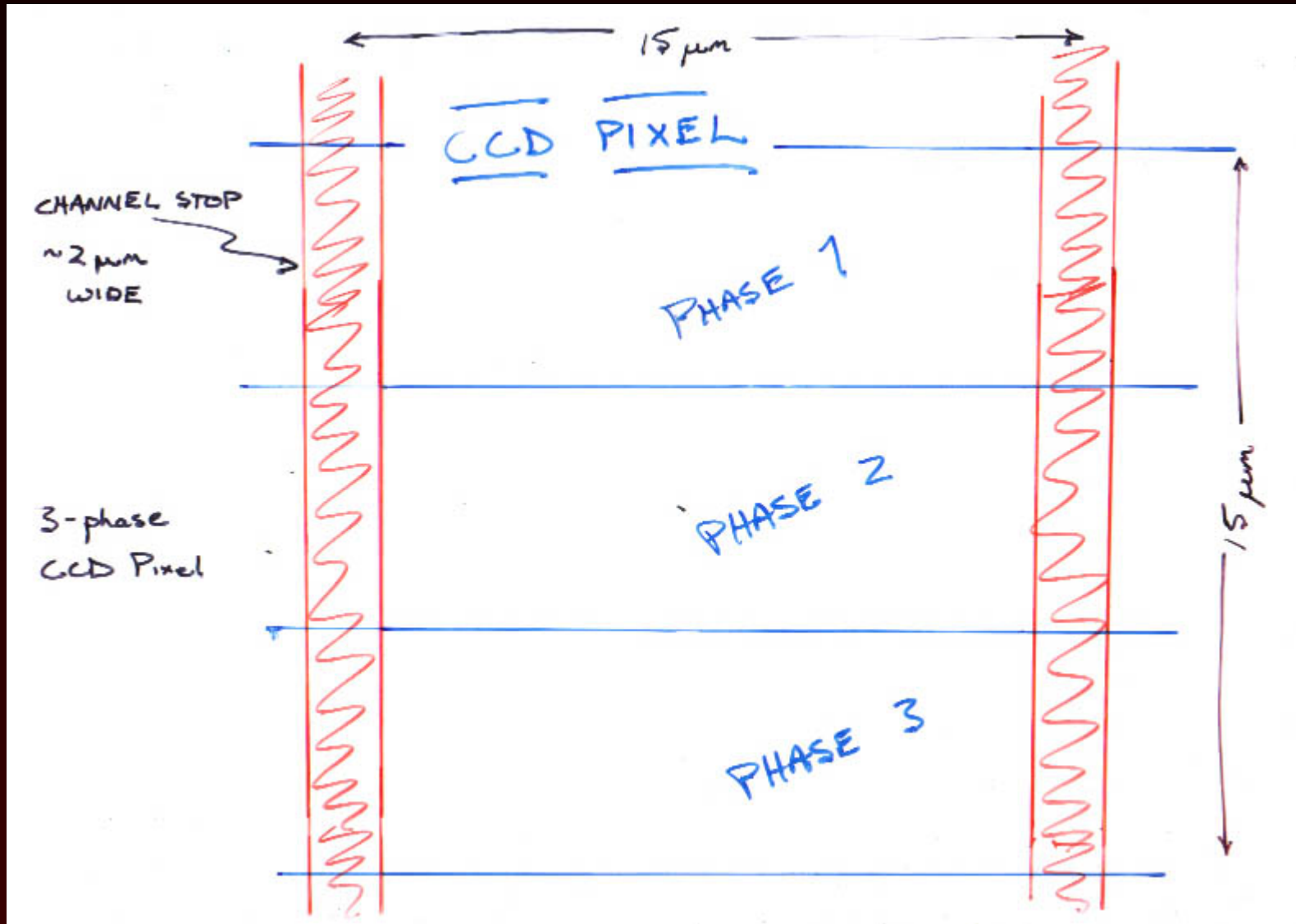

Periodic Table

1 H Hydrogen 1.0																	2 He Helium 4.0
3 Li Lithium 6.9	4 Be Beryllium 9.0											5 B Boron 10.8	6 C Carbon 12.0	7 N Nitrogen 14.0	8 O Oxygen 16.0	9 F Fluorine 19.0	10 Ne Neon 20.2
11 Na Sodium 23.0	12 Mg Magnesium 9.0											13 Al Aluminum 27.0	14 Si Silicon 28.1	15 P Phosphorus 31.0	16 S Sulfur 32.1	17 Cl Chlorine 35.5	18 Ar Argon 40.0
19 K Potassium 39.1	20 Ca Calcium 40.2	21 Sc Scandium 45.0	22 Ti Titanium 47.9	23 V Vanadium 50.9	24 Cr Chromium 52.0	25 Mn Manganese 54.9	26 Fe Iron 55.9	27 Co Cobalt 58.9	28 Ni Nickel 58.7	29 Cu Copper 63.5	30 Zn Zinc 65.4	31 Ga Gallium 69.7	32 Ge Germanium 72.6	33 As Arsenic 74.9	34 Se Selenium 79.0	35 Br Bromine 79.9	36 Kr Krypton 83.8
37 Rb Rubidium 85.5	38 Sr Strontium 87.6	39 Y Yttrium 88.9	40 Zr Zirconium 91.2	41 Nb Niobium 92.9	42 Mo Molybdenum 95.9	43 Tc Technetium 99	44 Ru Ruthenium 101.0	45 Rh Rhodium 102.9	46 Pd Palladium 106.4	47 Ag Silver 107.9	48 Cd Cadmium 112.4	49 In Indium 114.8	50 Sn Tin 118.7	51 Sb Antimony 121.8	52 Te Tellurium 127.6	53 I Iodine 126.9	54 Xe Xenon 131.3
55 Cs Caesium 132.9	56 Ba Barium 137.4	57-71 Lanthanides	72 Hf Hafnium 178.5	73 Ta Tantalum 181.0	74 W Tungsten 183.9	75 Re Rhenium 186.2	76 Os Osmium 190.2	77 Ir Iridium 192.2	78 Pt Platinum 195.1	79 Au Gold 197.0	80 Hg Mercury 200.6	81 Tl Thallium 204.4	82 Pb Lead 207.2	83 Bi Bismuth 209.0	84 Po Polonium 210.0	85 At Astatine 210.0	86 Rn Radon 222.0
87 Fr Francium 223.0	88 Ra Radium 226.0	89-103 Actinides	104 Rf Rutherfordium 261	105 Db Dubnium 262	106 Sg Seaborgium 263	107 Bh Bohrium 262	108 Hs Hassium 265	109 Mt Meitnerium 266	110 Uun Ununillium 272								

Types of Elements Key:

- Alkali metals
- Alkaline earth metals
- Transition metals
- Lanthanides
- Actinides
- Poor metals
- Semi-metals
- Non-metals
- Noble gases

57 La Lanthanum 138.9	58 Ce Cerium 140.1	59 Pr Praseodymium 140.9	60 Nd Neodymium 144.2	61 Pm Promethium 147.0	62 Sm Samarium 150.4	63 Eu Europium 152.0	64 Gd Gadolinium 157.3	65 Tb Terbium 158.9	66 Dy Dysprosium 162.5	67 Ho Holmium 164.9	68 Er Erbium 167.3	69 Tm Thulium 168.9	70 Yb Ytterbium 173.0	71 Lu Lutetium 175.0
89 Ac Actinium 132.9	90 Th Thorium 232.0	91 Pa Protactinium 231.0	92 U Uranium 238.0	93 Np Neptunium 237.0	94 Pu Plutonium 242.0	95 Am Americium 243.0	96 Cm Curium 247.0	97 Bk Berkelium 247.0	98 Cf Californium 251.0	99 Es Einsteinium 254.0	100 Fm Fermium 253.0	101 Md Mendelevium 256.0	102 No Nobelium 254.0	103 Lr Lawrencium 257.0

Periodic Table

1 H Hydrogen 1.0											2 He Helium 4.0						
3 Li Lithium 6.9	4 Be Beryllium 9.0											5 B Boron 10.8	6 C Carbon 12.0	7 N Nitrogen 14.0	8 O Oxygen 16.0	9 F Fluorine 19.0	10 Ne Neon 20.2
11 Na Sodium 23.0	12 Mg Magnesium 9.0											13 Al Aluminum 27.0	14 Si Silicon 28.1	15 P Phosphorus 31.0	16 S Sulfur 32.1	17 Cl Chlorine 35.5	18 Ar Argon 40.0
19 K Potassium 39.1	20 Ca Calcium 40.2	21 Sc Scandium 45.0	22 Ti Titanium 47.9	23 V Vanadium 50.9	24 Cr Chromium 52.0	25 Mn Manganese 54.9	26 Fe Iron 55.9	27 Co Cobalt 58.9	28 Ni Nickel 58.7	29 Cu Copper 63.5	30 Zn Zinc 65.4	31 Ga Gallium 69.7	32 Ge Germanium 72.6	33 As Arsenic 74.9	34 Se Selenium 79.0	35 Br Bromine 79.9	36 Kr Krypton 83.8
37 Rb Rubidium 85.5	38 Sr Strontium 87.6	39 Y Yttrium 88.9	40 Zr Zirconium 91.2	41 Nb Niobium 92.9	42 Mo Molybdenum 95.9	43 Tc Technetium 99	44 Ru Ruthenium 101.0	45 Rh Rhodium 102.9	46 Pd Palladium 106.4	47 Ag Silver 107.9	48 Cd Cadmium 112.4	49 In Indium 114.8	50 Sn Tin 118.7	51 Sb Antimony 121.8	52 Te Tellurium 127.6	53 I Iodine 126.9	54 Xe Xenon 131.3
55 Cs Caesium 132.9	56 Ba Barium 137.4	57-71 Lanthanides	72 Hf Hafnium 178.5	73 Ta Tantalum 181.0	74 W Tungsten 183.9	75 Re Rhenium 186.2	76 Os Osmium 190.2	77 Ir Iridium 192.2	78 Pt Platinum 195.1	79 Au Gold 197.0	80 Hg Mercury 200.6	81 Tl Thallium 204.4	82 Pb Lead 207.2	83 Bi Bismuth 209.0	84 Po Polonium 210.0	85 At Astatine 210.0	86 Rn Radon 222.0
87 Fr Francium 223.0	88 Ra Radium 226.0	89-103 Actinides	104 Rf Rutherfordium 261	105 Db Dubnium 262	106 Sg Seaborgium 263	107 Bh Bohrium 262	108 Hs Hassium 265	109 Mt Meitnerium 266	110 Uun Ununillium 272								

Types of Elements Key:

- Alkali metals
- Alkaline earth metals
- Transition metals
- Lanthanides
- Actinides
- Poor metals
- Semi-metals
- Non-metals
- Noble gases

57 La Lanthanum 138.9	58 Ce Cerium 140.1	59 Pr Praseodymium 140.9	60 Nd Neodymium 144.2	61 Pm Promethium 147.0	62 Sm Samarium 150.4	63 Eu Europium 152.0	64 Gd Gadolinium 157.3	65 Tb Terbium 158.9	66 Dy Dysprosium 162.5	67 Ho Holmium 164.9	68 Er Erbium 167.3	69 Tm Thulium 168.9	70 Yb Ytterbium 173.0	71 Lu Lutetium 175.0
89 Ac Actinium 132.9	90 Th Thorium 232.0	91 Pa Protactinium 231.0	92 U Uranium 238.0	93 Np Neptunium 237.0	94 Pu Plutonium 242.0	95 Am Americium 243.0	96 Cm Curium 247.0	97 Bk Berkelium 247.0	98 Cf Californium 251.0	99 Es Einsteinium 254.0	100 Fm Fermium 253.0	101 Md Mendelevium 256.0	102 No Nobelium 254.0	103 Lr Lawrencium 257.0

Periodic Table

											2 He Helium 4.0
						5 B Boron 10.8	6 C Carbon 12.0	7 N Nitrogen 14.0	8 O Oxygen 16.0	9 F Fluorine 19.0	10 Ne Neon 20.2
						13 Al Aluminum 27.0	14 Si Silicon 28.1	15 P Phosphorus 31.0	16 S Sulfur 32.1	17 Cl Chlorine 35.5	18 Ar Argon 40.0
	26 Fe Iron 55.9	27 Co Cobalt 58.9	28 Ni Nickel 58.7	29 Cu Copper 63.5	30 Zn Zinc 65.4	31 Ga Gallium 69.7	32 Ge Germanium 72.6	33 As Arsenic 74.9	34 Se Selenium 79.0	35 Br Bromine 79.9	36 Kr Krypton 83.8
	44 Ru Ruthenium 101.0	45 Rh Rhodium 102.9	46 Pd Palladium 106.4	47 Ag Silver 107.9	48 Cd Cadmium 112.4	49 In Indium 114.8	50 Sn Tin 118.7	51 Sb Antimony 121.8	52 Te Tellurium 127.6	53 I Iodine 126.9	54 Xe Xenon 131.3
	76 Os Osmium 190.2	77 Ir Iridium 192.2	78 Pt Platinum 195.1	79 Au Gold 197.0	80 Hg Mercury 200.6	81 Tl Thallium 204.4	82 Pb Lead 207.2	83 Bi Bismuth 209.0	84 Po Polonium 210.0	85 At Astatine 210.0	86 Rn Radon 222.0
	108 Hs Hassium 265	109 Mt Meitnerium 266	110 Uun Ununnilium 272								

Types of Elements Key:

 Alkalimetals

Periodic Table

										2 He Helium 4.0	
						5 B Boron 10.8	6 C Carbon 12.0	7 N Nitrogen 14.0	8 O Oxygen 16.0	9 F Fluorine 19.0	10 Ne Neon 20.2
						13 Al Aluminum 27.0	14 Si Silicon 28.1	15 P Phosphorus 31.0	16 S Sulfur 32.1	17 Cl Chlorine 35.5	18 Ar Argon 40.0
	26 Fe Iron 55.9	27 Co Cobalt 58.9	28 Ni Nickel 58.7	29 Cu Copper 63.5	30 Zn Zinc 65.4	31 Ga Gallium 69.7	32 Ge Germanium 72.6	33 As Arsenic 74.9	34 Se Selenium 79.0	35 Br Bromine 79.9	36 Kr Krypton 83.8
	44 Ru Ruthenium 101.0	45 Rh Rhodium 102.9	46 Pd Palladium 106.4	47 Ag Silver 107.9	48 Cd Cadmium 112.4	49 In Indium 114.8	50 Sn Tin 118.7	51 Sb Antimony 121.8	52 Te Tellurium 127.6	53 I Iodine 126.9	54 Xe Xenon 131.3
	76 Os Osmium 190.2	77 Ir Iridium 192.2	78 Pt Platinum 195.1	79 Au Gold 197.0	80 Hg Mercury 200.6	81 Tl Thallium 204.4	82 Pb Lead 207.2	83 Bi Bismuth 209.0	84 Po Polonium 210.0	85 At Astatine 210.0	86 Rn Radon 222.0
	108 Hs Hassium 265	109 Mt Meitnerium 266	110 Uun Ununnilium 272								

Types of Elements Key:

Alkalimetals

CCD Pixel Architecture – column boundaries

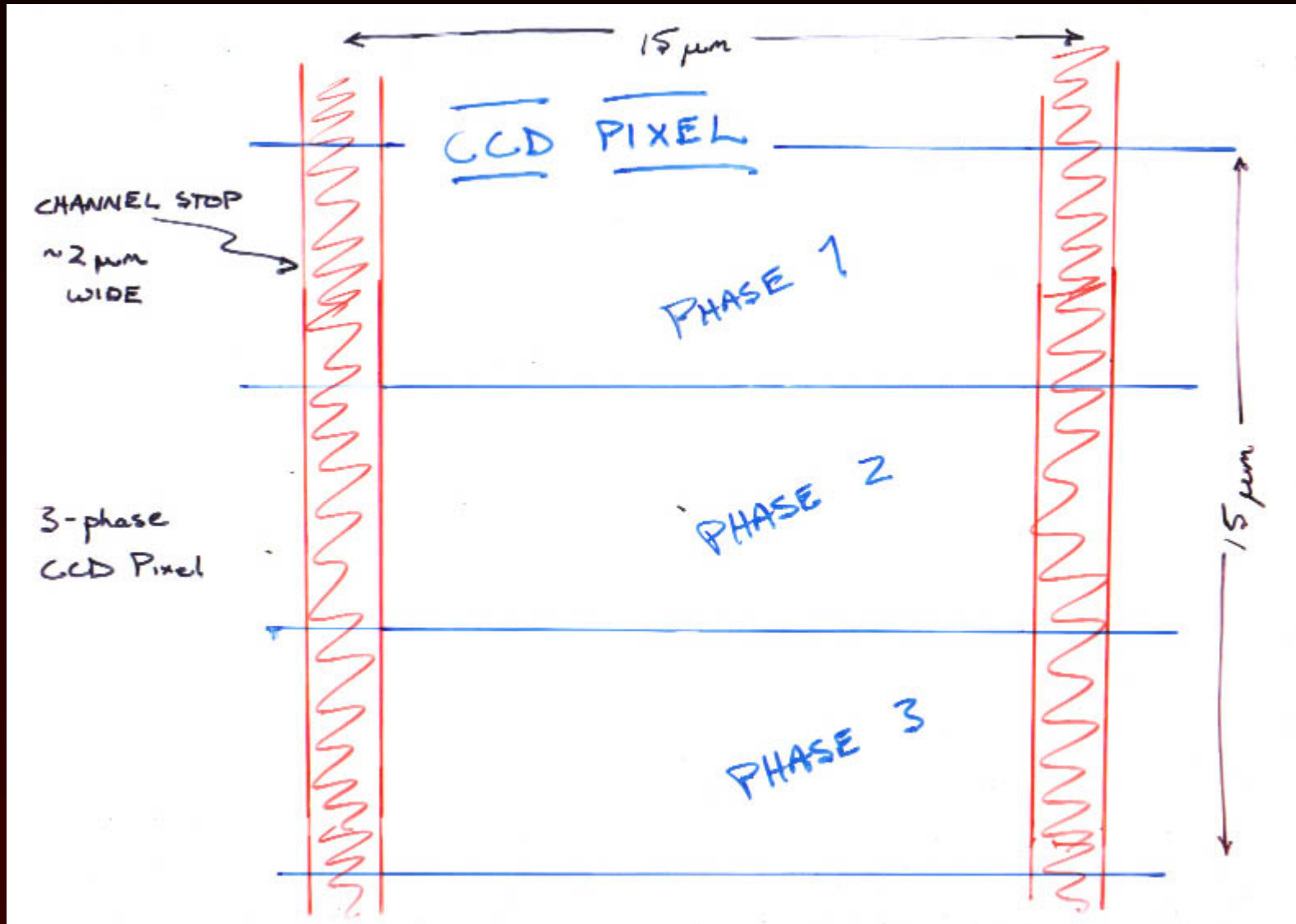

Periodic Table

											2 He Helium 4.0
						5 B Boron 10.8	6 C Carbon 12.0	7 N Nitrogen 14.0	8 O Oxygen 16.0	9 F Fluorine 19.0	10 Ne Neon 20.2
						13 Al Aluminum 27.0	14 Si Silicon 28.1	15 P Phosphorus 31.0	16 S Sulfur 32.1	17 Cl Chlorine 35.5	18 Ar Argon 40.0
	26 Fe Iron 55.9	27 Co Cobalt 58.9	28 Ni Nickel 58.7	29 Cu Copper 63.5	30 Zn Zinc 65.4	31 Ga Gallium 69.7	32 Ge Germanium 72.6	33 As Arsenic 74.9	34 Se Selenium 79.0	35 Br Bromine 79.9	36 Kr Krypton 83.8
	44 Ru Ruthenium 101.0	45 Rh Rhodium 102.9	46 Pd Palladium 106.4	47 Ag Silver 107.9	48 Cd Cadmium 112.4	49 In Indium 114.8	50 Sn Tin 118.7	51 Sb Antimony 121.8	52 Te Tellurium 127.6	53 I Iodine 126.9	54 Xe Xenon 131.3
	76 Os Osmium 190.2	77 Ir Iridium 192.2	78 Pt Platinum 195.1	79 Au Gold 197.0	80 Hg Mercury 200.6	81 Tl Thallium 204.4	82 Pb Lead 207.2	83 Bi Bismuth 209.0	84 Po Polonium 210.0	85 At Astatine 210.0	86 Rn Radon 222.0
	108 Hs Hassium 265	109 Mt Meitnerium 266	110 Uun Ununnilium 272								

Types of Elements Key:



Alkalimetals

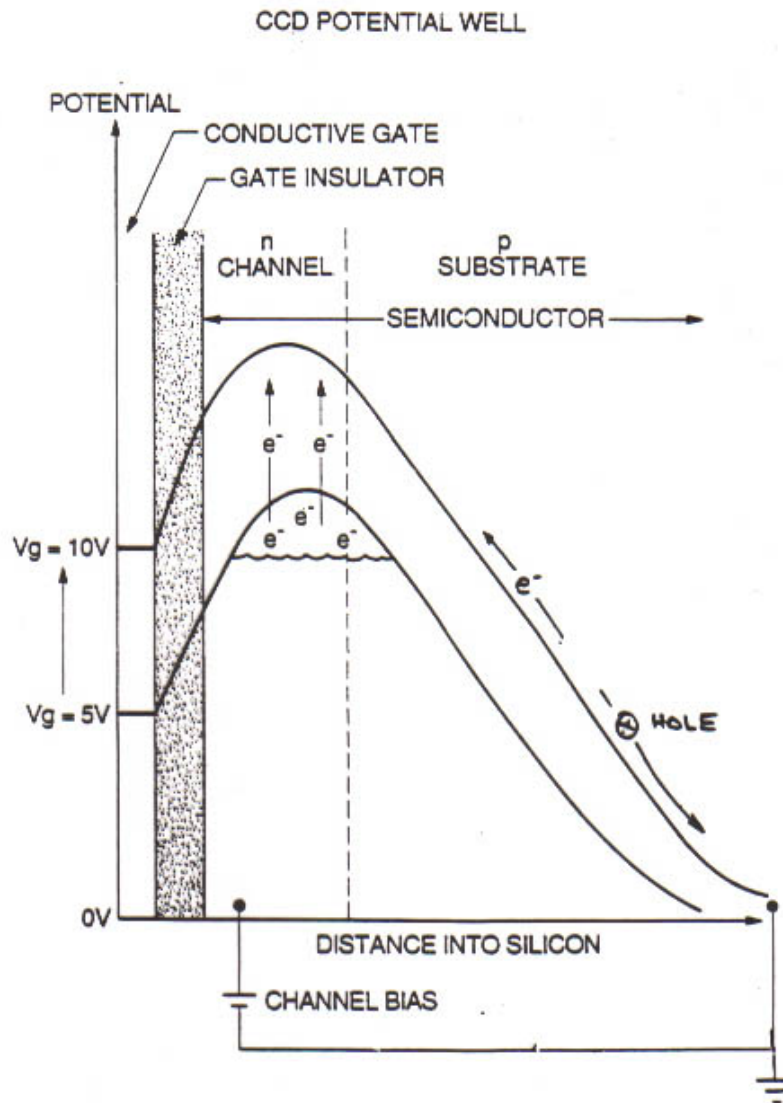

A BURIED CHANNEL CCD

n - phosphorous
p - boron

For silicon

n – region from phosphorous doping

p – region from boron doping

n-channel CCD
collects electrons

p-channel CCD
collect holes

CCD Pixel Architecture – parallel phases

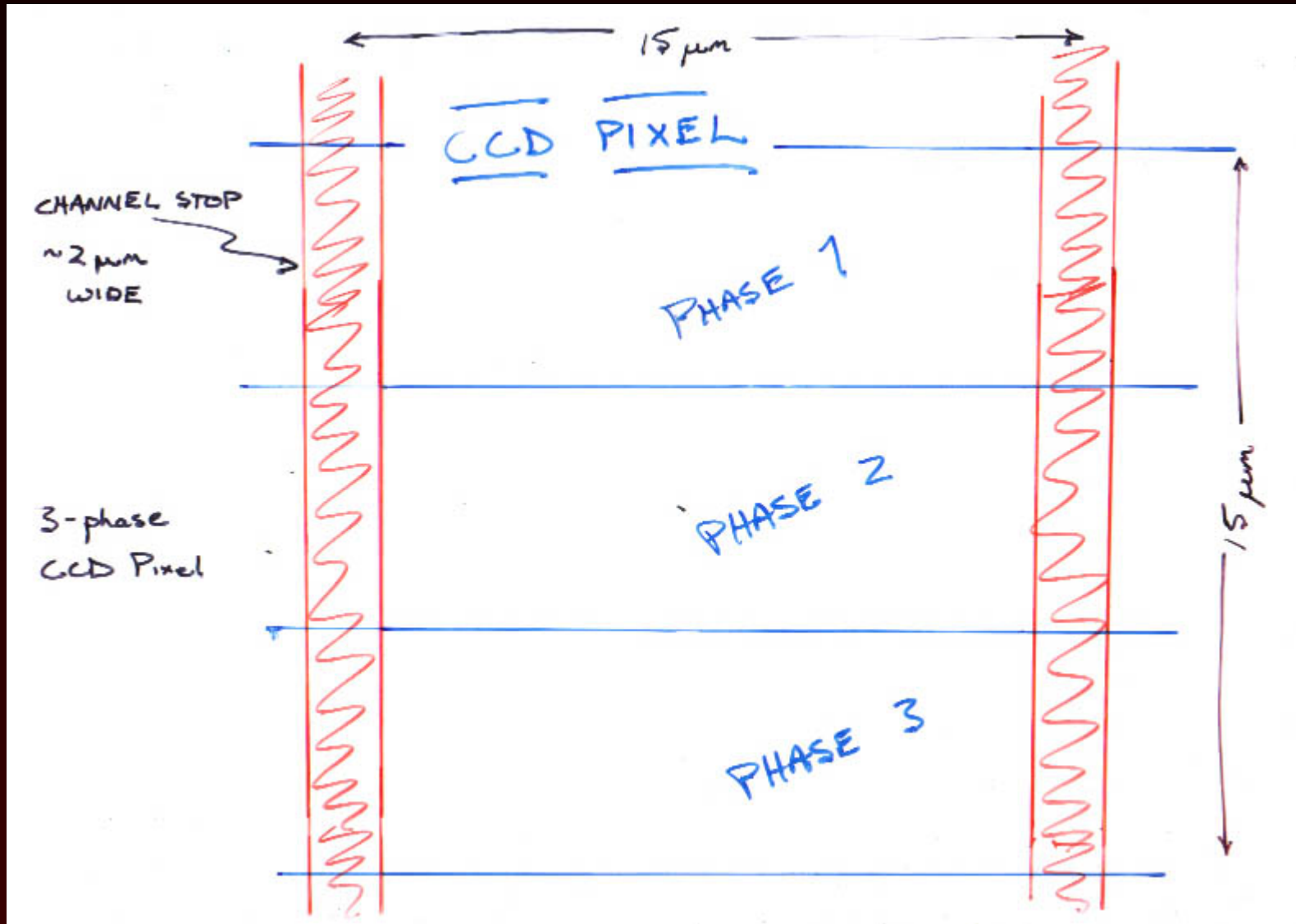

CCD Fabrication Process

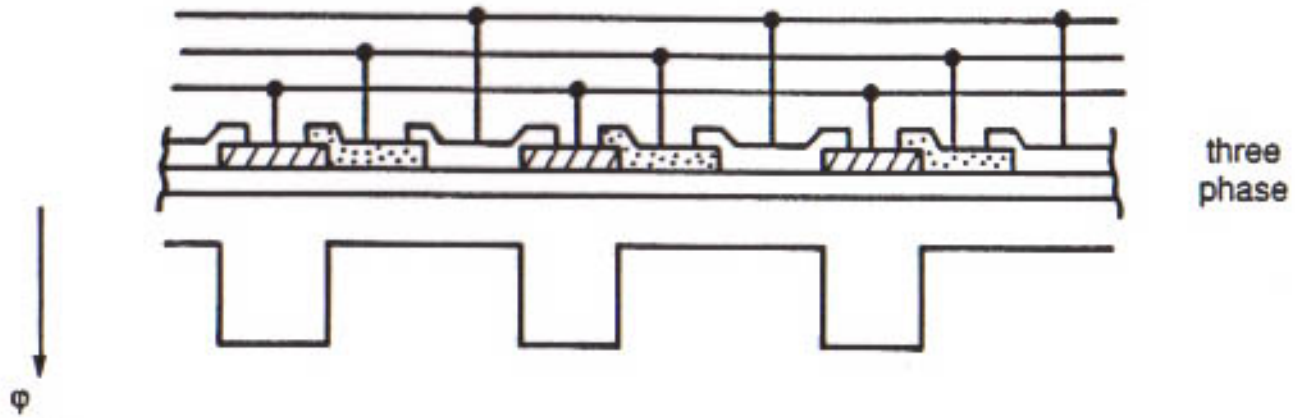

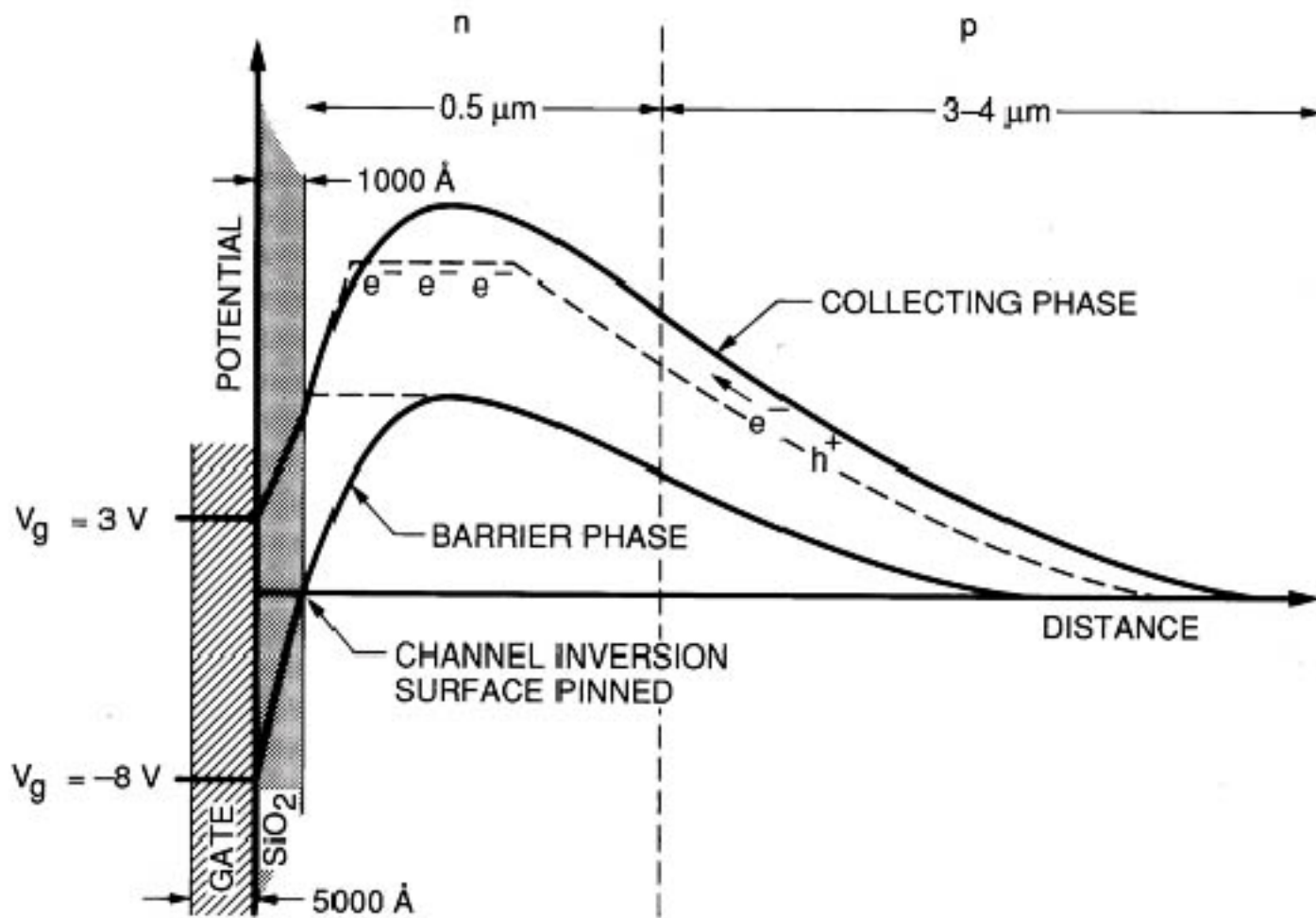

Step 4: Charge transfer

- IR detectors have amplifier at each pixel, so no need for charge transfer.
- CCDs must move charge across the focal plane array to the readout amplifier.

CCD Architecture

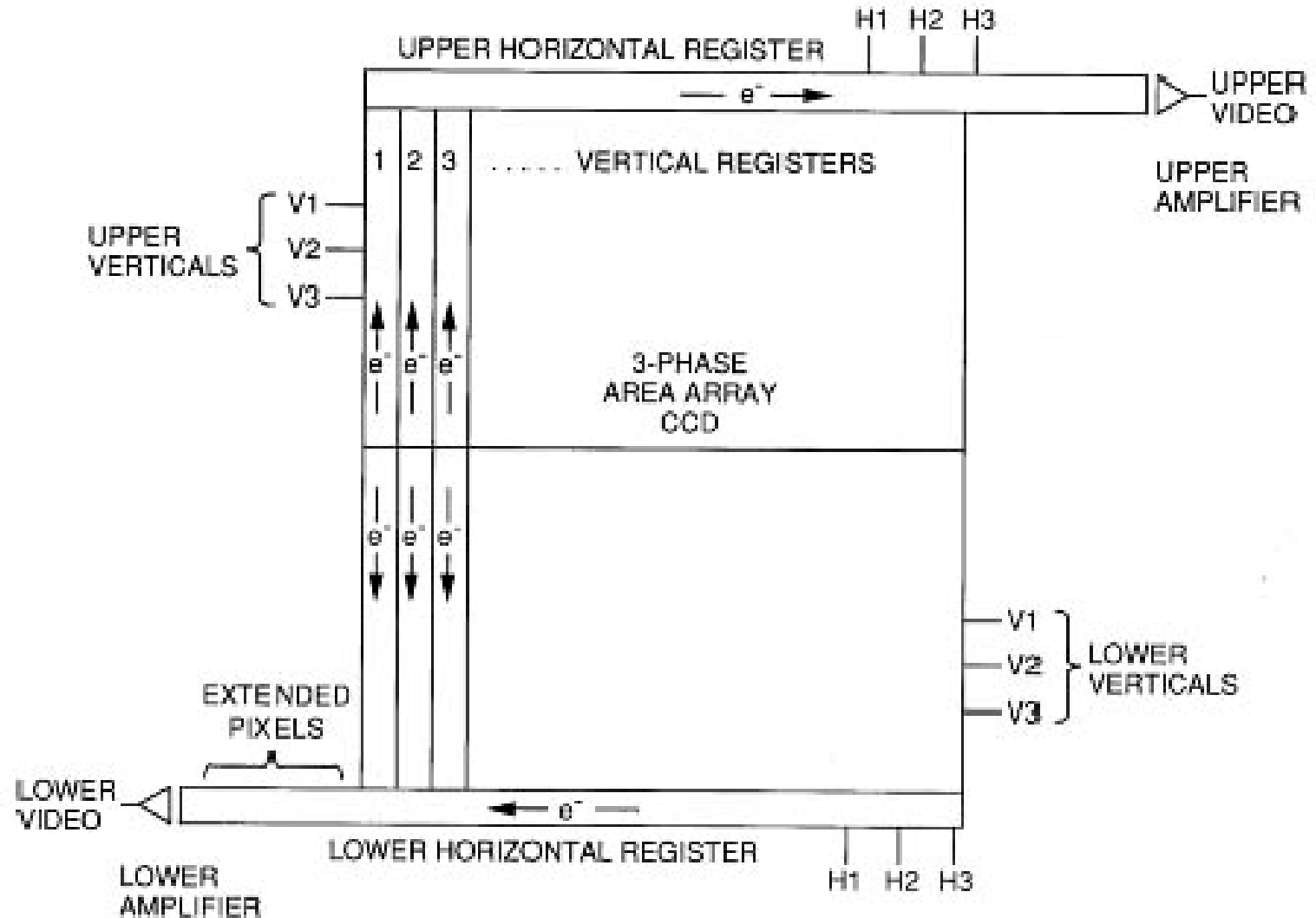

CCD Charge transfer

The good, the bad & the ugly

- “Bad & ugly” aspects of charge transfer
 - Takes time
 - Can blur image if no shutter used
 - Can lose / blur charge during move
 - Can bleed charge from saturated pixel up/down column
 - Can have a blocked column
 - Can have a hot pixel that releases charge into all passing pixels
- “Good” aspects of charge transfer
 - Can bin charge “on-chip” – noiseless process
 - Can charge shift for tip/tilt correction or to eliminate systematic errors (“va-et-vient”, “nod-and-shuffle”)
 - Can build special purpose designs that integrate different areas depending on application (curvature wavefront sensing, Shack-Hartmann laser guide star wavefront sensing)
 - Can do drift scanning
 - Have space to build a great low noise amplifier !

CCD Timing

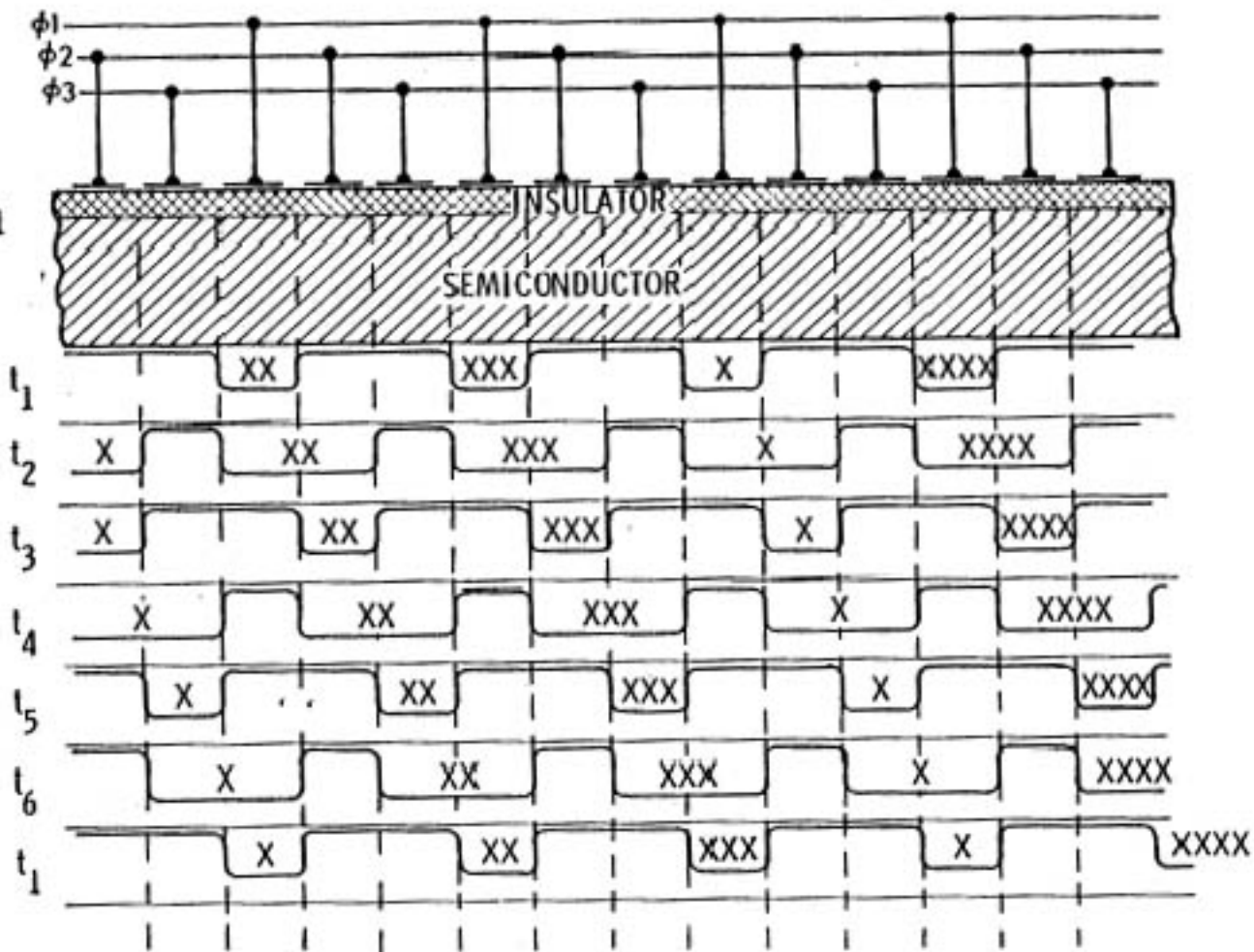
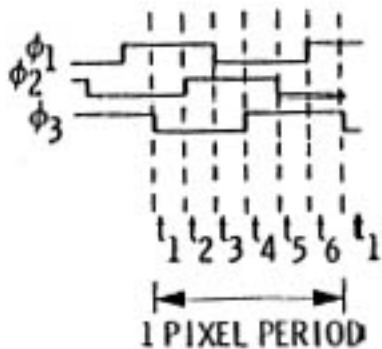

Movement
of charge
is "coupled"

Charge
Coupled
Device

3-Phase serial register

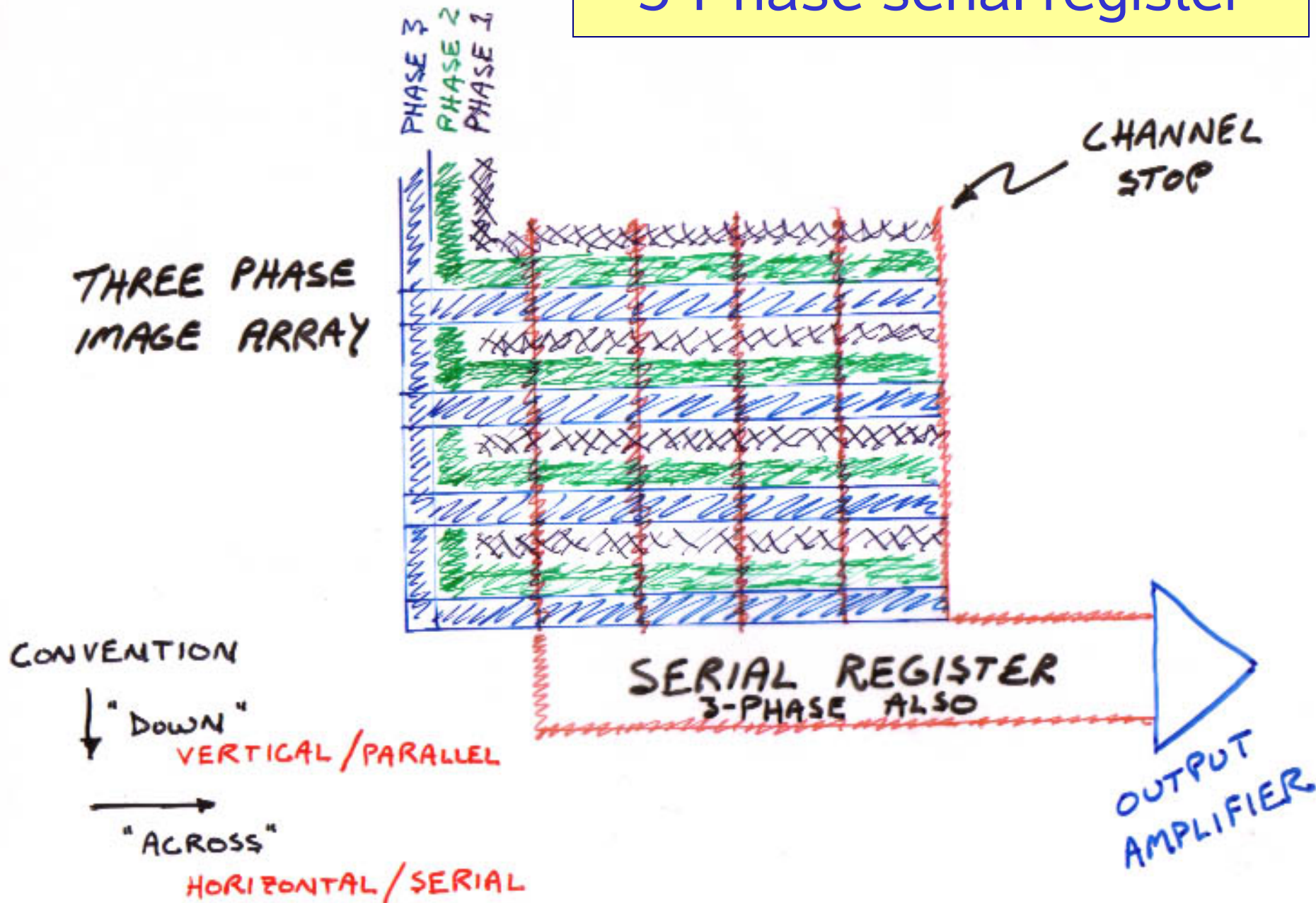

Rain bucket analogy

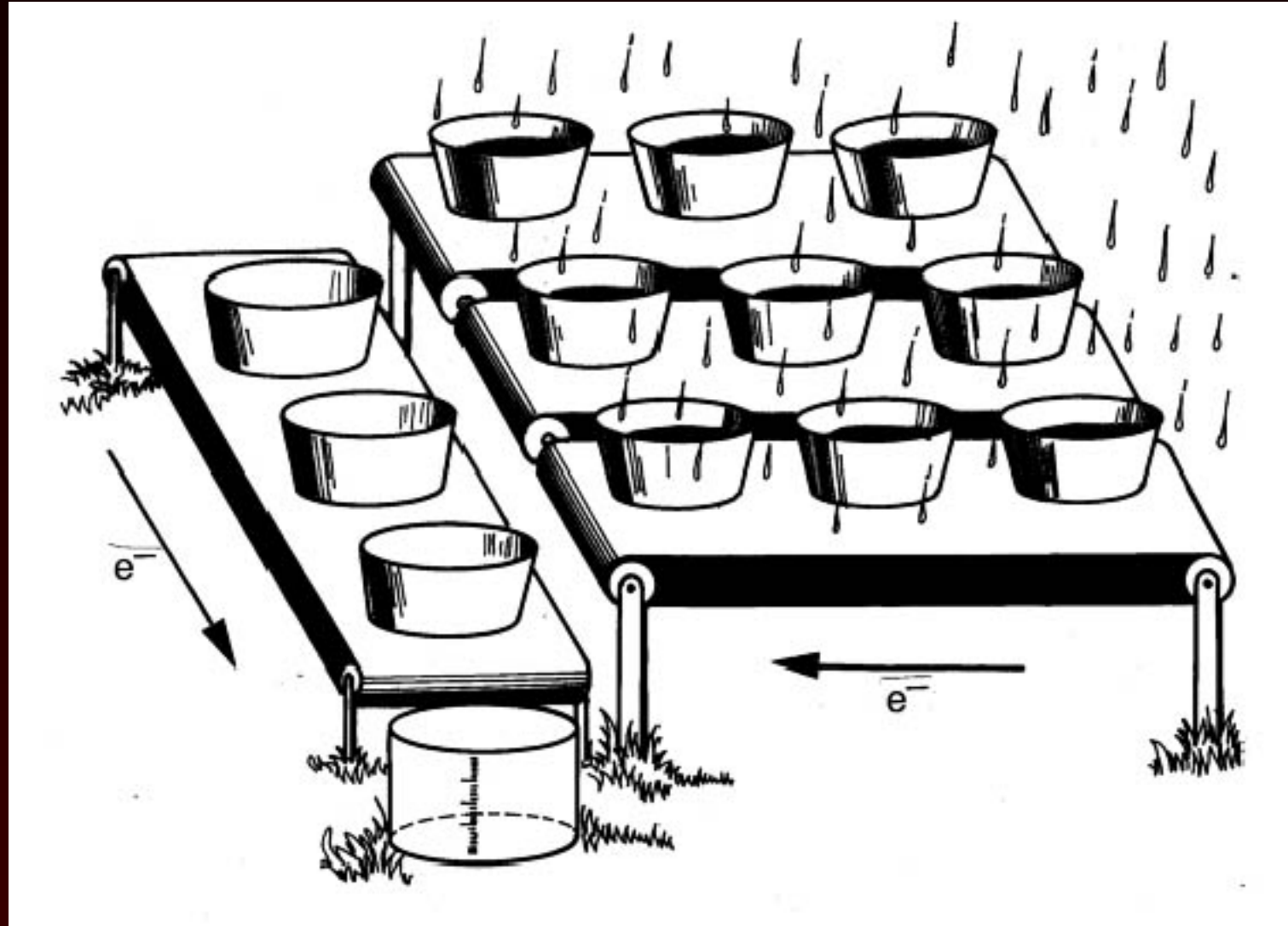

CCD Architecture

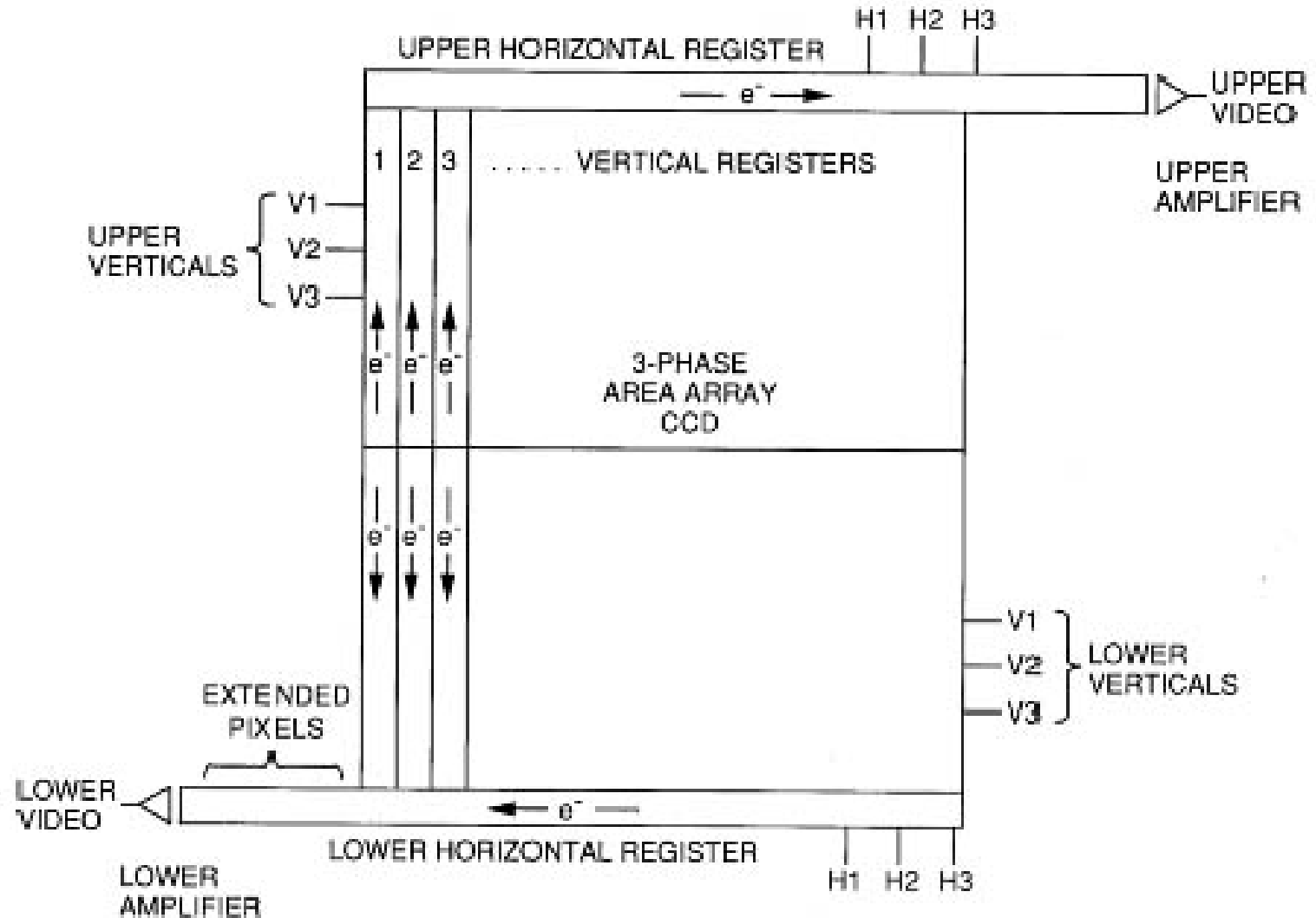

Step 5: Charge amplification

- Similar for CCDs and IR detectors.
- Both use MOSFETs (metal-oxide-silicon field effect transistors) to amplify the signal.
- Show CCD amplifier first and then relate to IR pixel.

CCD – Serial register and amplifier

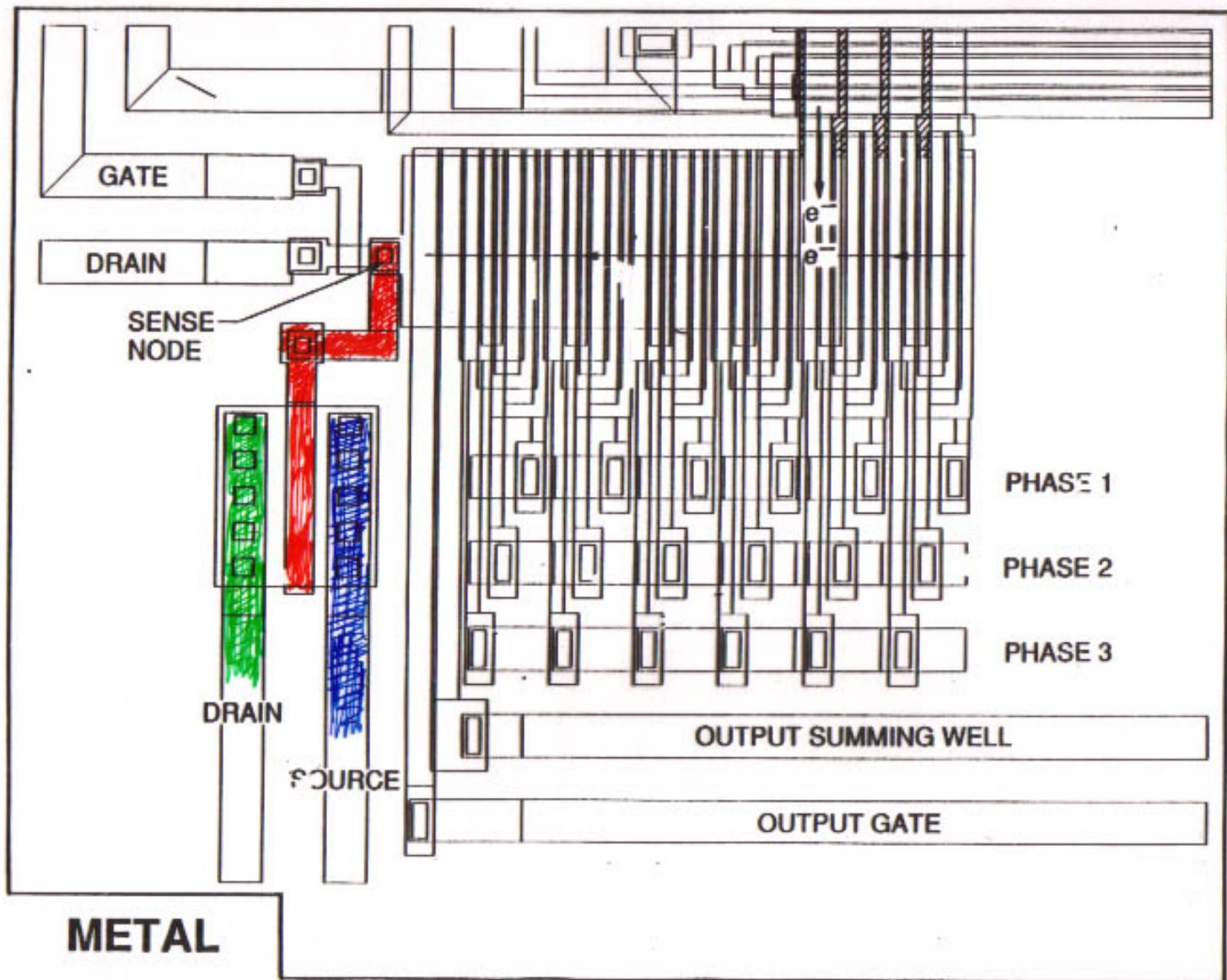

GRAF/CASSINI CCD

200X S4613

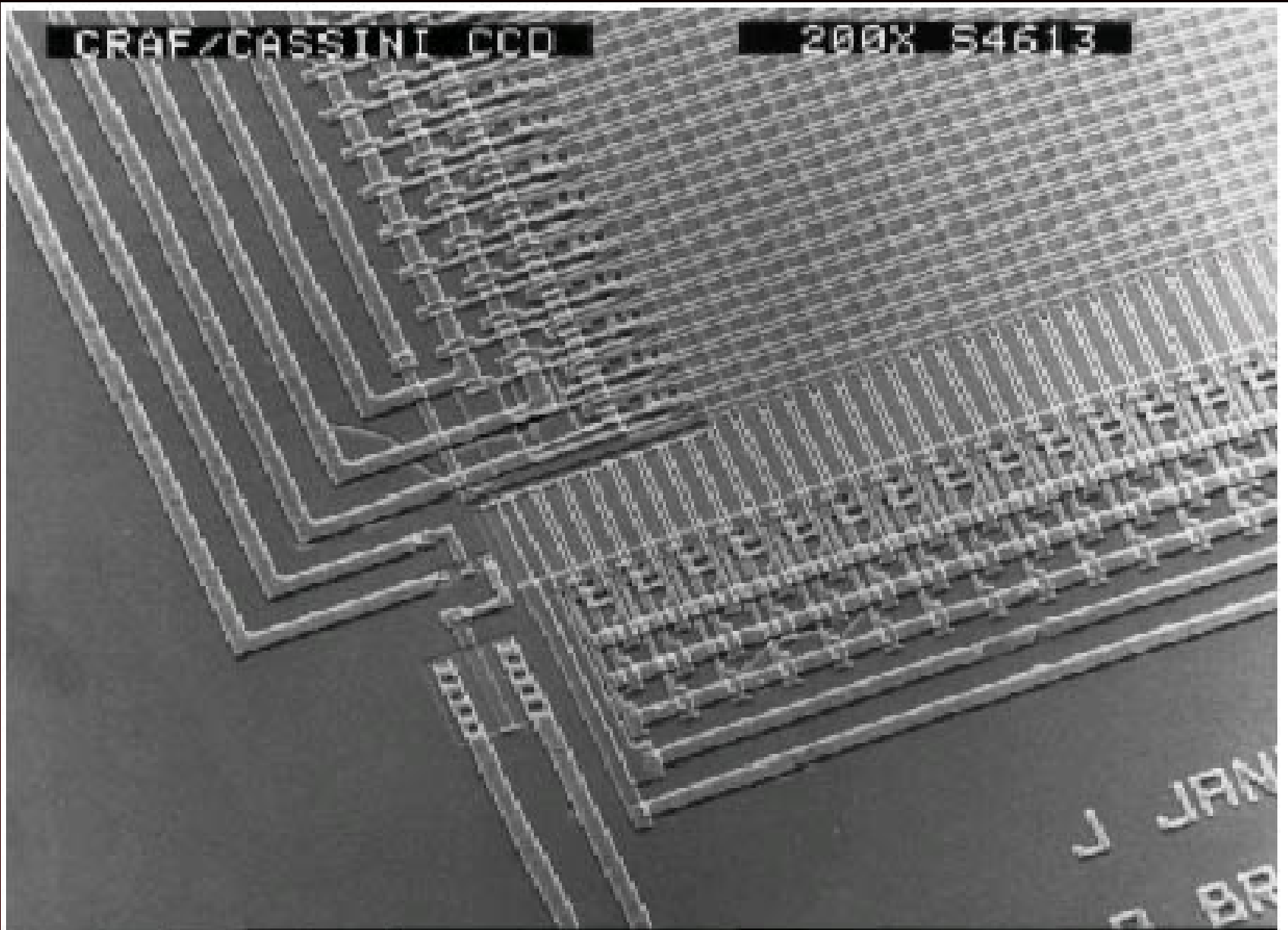

100µM

20KV

45

029

S

CRAF/CASSINI CCD

200X S4613

100 micron diameter human hair

100µm

20KV

45

029

S

J JAN
BR

CRAF/CASSINI CCD

200X S4613

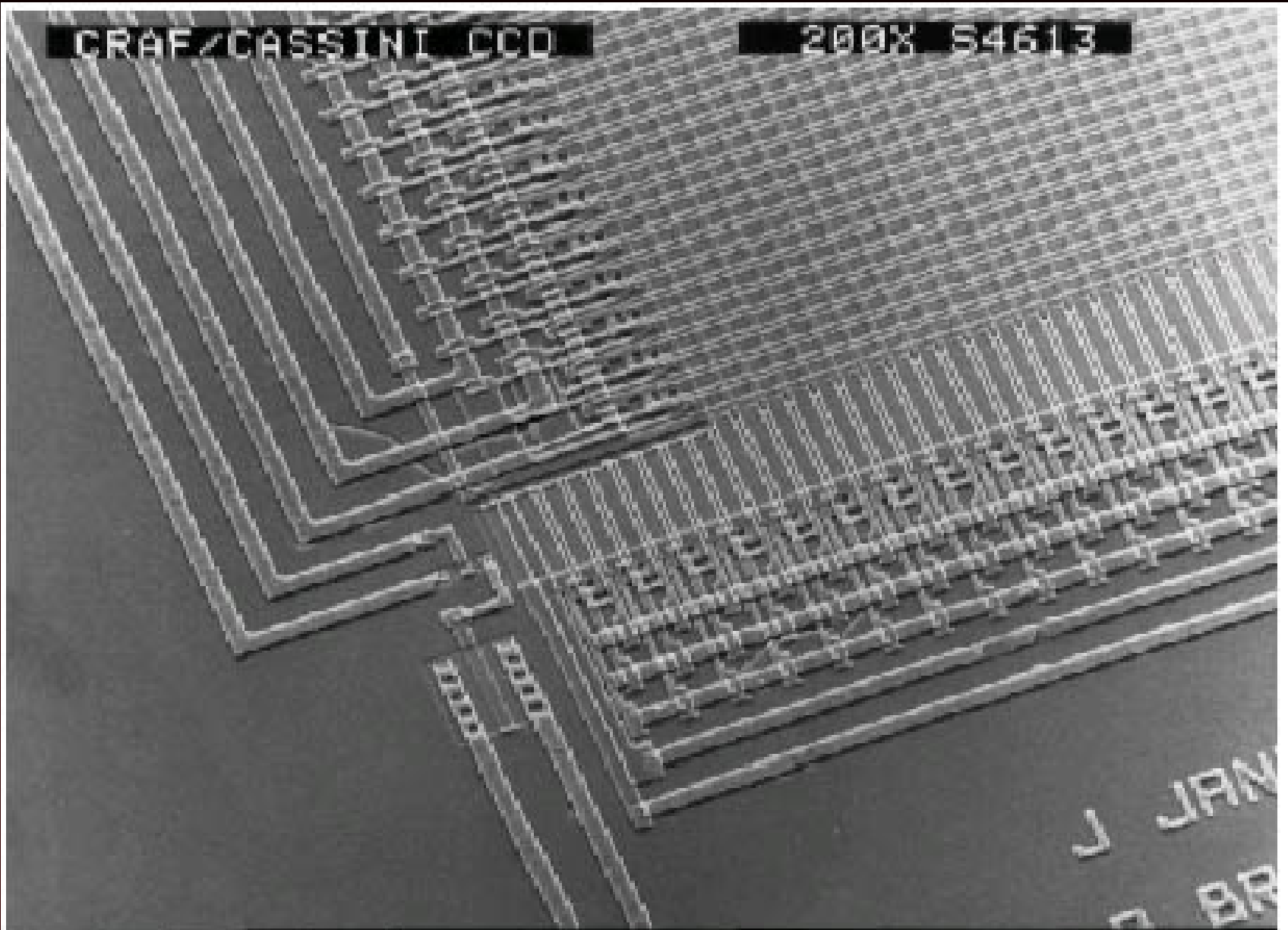

100µM

20KV

45

029

S

J JAN
BR

CRAF/CASSINI CCD

600X S4613

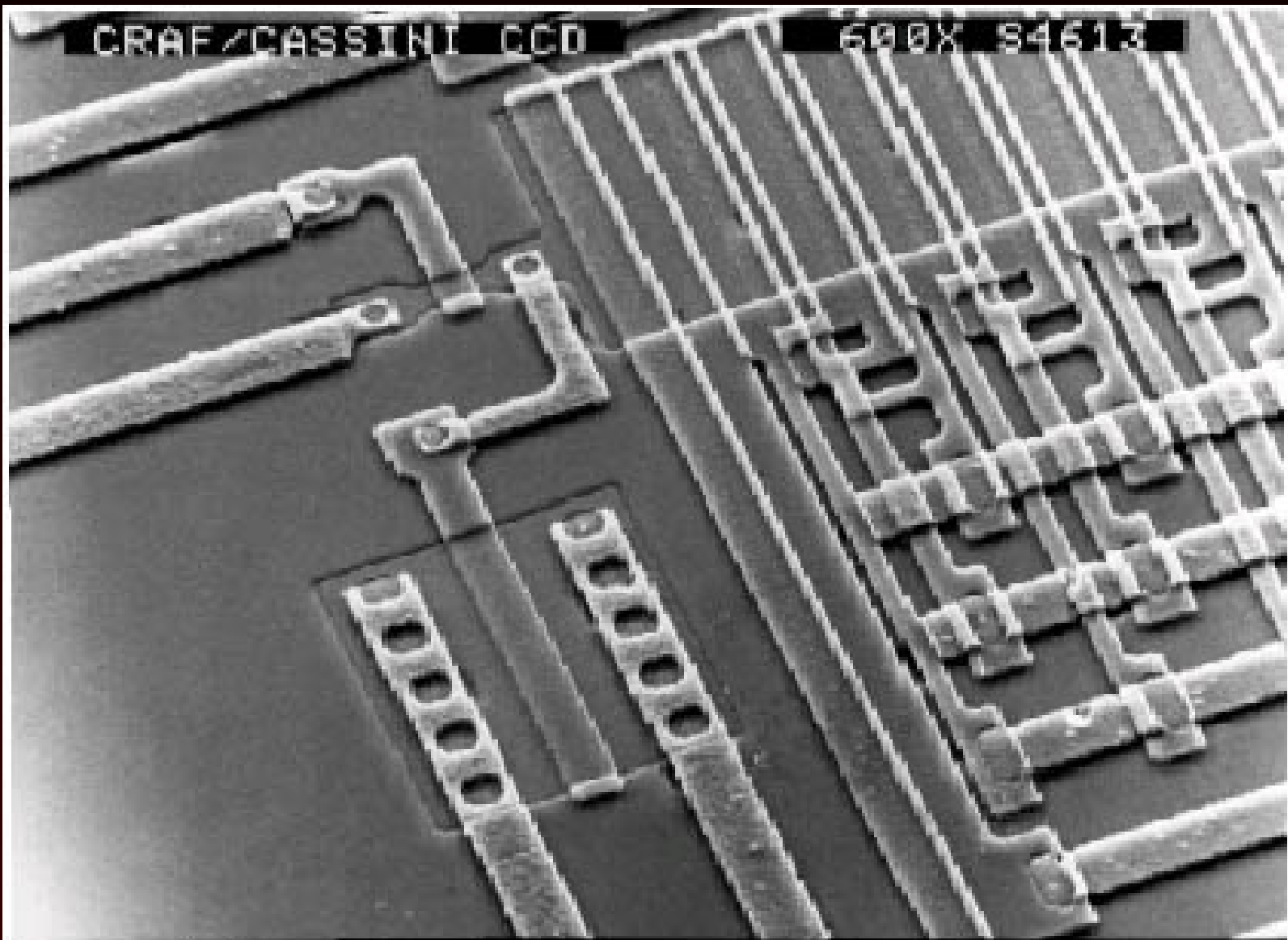

40PM

20KV

45

026

S

FOR SiTe type amplifier : $4 \times 25 \mu\text{m}$ gate, $\frac{1}{2} \mu\text{m}$ thick, 10^{20} doping
 $3 \times 10 \mu\text{m}$ Al strap, $\frac{1}{2} \mu\text{m}$ thick
 Capacitance (gate) $\approx 100 \text{ fF}$, $1 \mu\text{V}/\text{e}^-$
 $\sim 5 \times 10^9$ phosphorous "donor" atoms on the gate
 $\sim 10^{12}$ conduction band electrons on the Al strap
 $\sim 6 \times 10^6$ electrons removed to bias to $+9\text{V}$

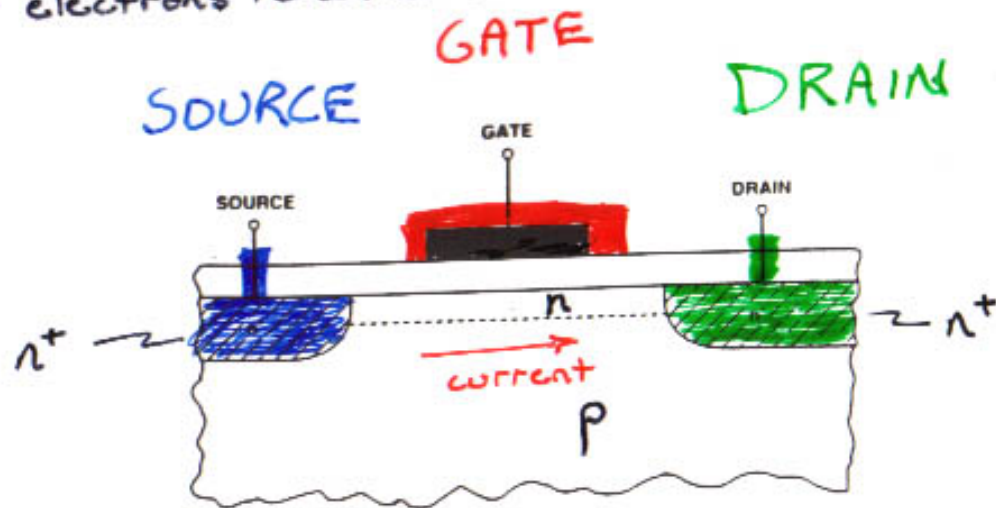

Fig. 4. Buried channel MOSFET with source and drain edges separated from the gate

FOR SiTe type amplifier : $4 \times 25 \mu\text{m}$ gate, $\frac{1}{2} \mu\text{m}$ thick, 10^{20} doping
 $3 \times 10 \mu\text{m}$ Al strap, $\frac{1}{2} \mu\text{m}$ thick
 Capacitance (gate) $\approx 100 \text{ fF}$, $1 \mu\text{V}/\text{e}^-$
 $\sim 5 \times 10^9$ phosphorous "donor" atoms on the gate
 $\sim 10^{12}$ conduction band electrons on the Al strap
 $\sim 6 \times 10^6$ electrons removed to bias to $+9\text{V}$

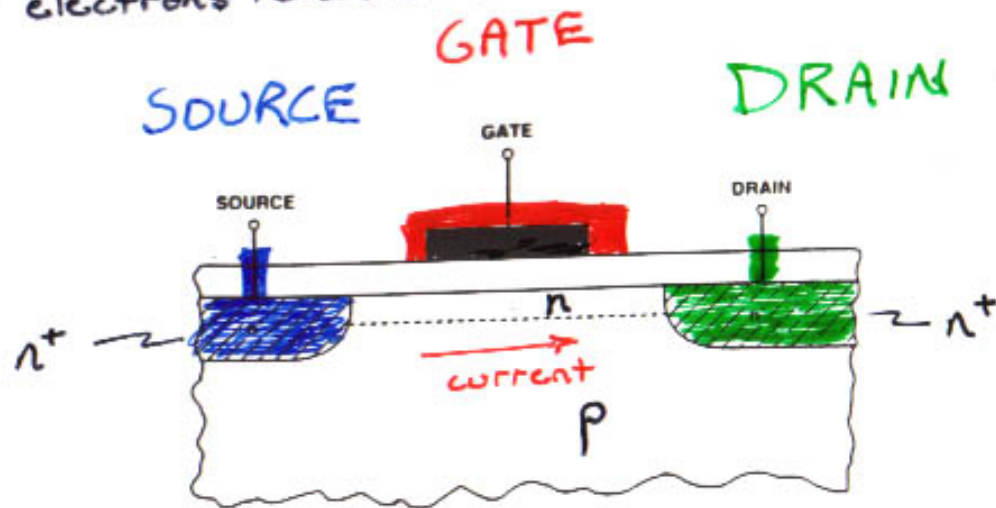
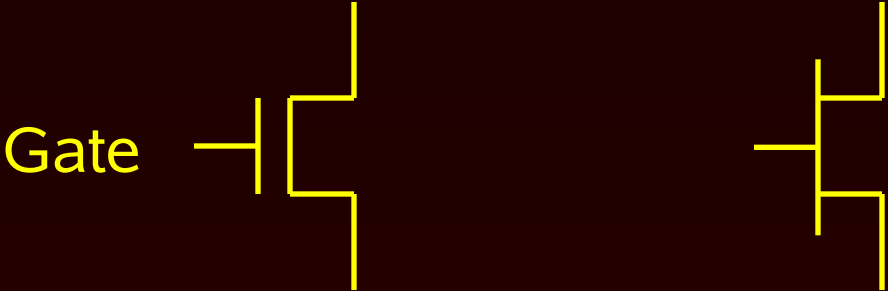

Fig. 4. Buried channel MOSFET with source and drain edges separated from the gate

Add 1 electron to the sense node and the flow of current under the MOSFET gate is reduced by 300 million per second!

MOSFET symbols

Source



- Dynamic range defined by linearity & noise -

Charge Detection

Sees all kinds of clock
feedthroughs

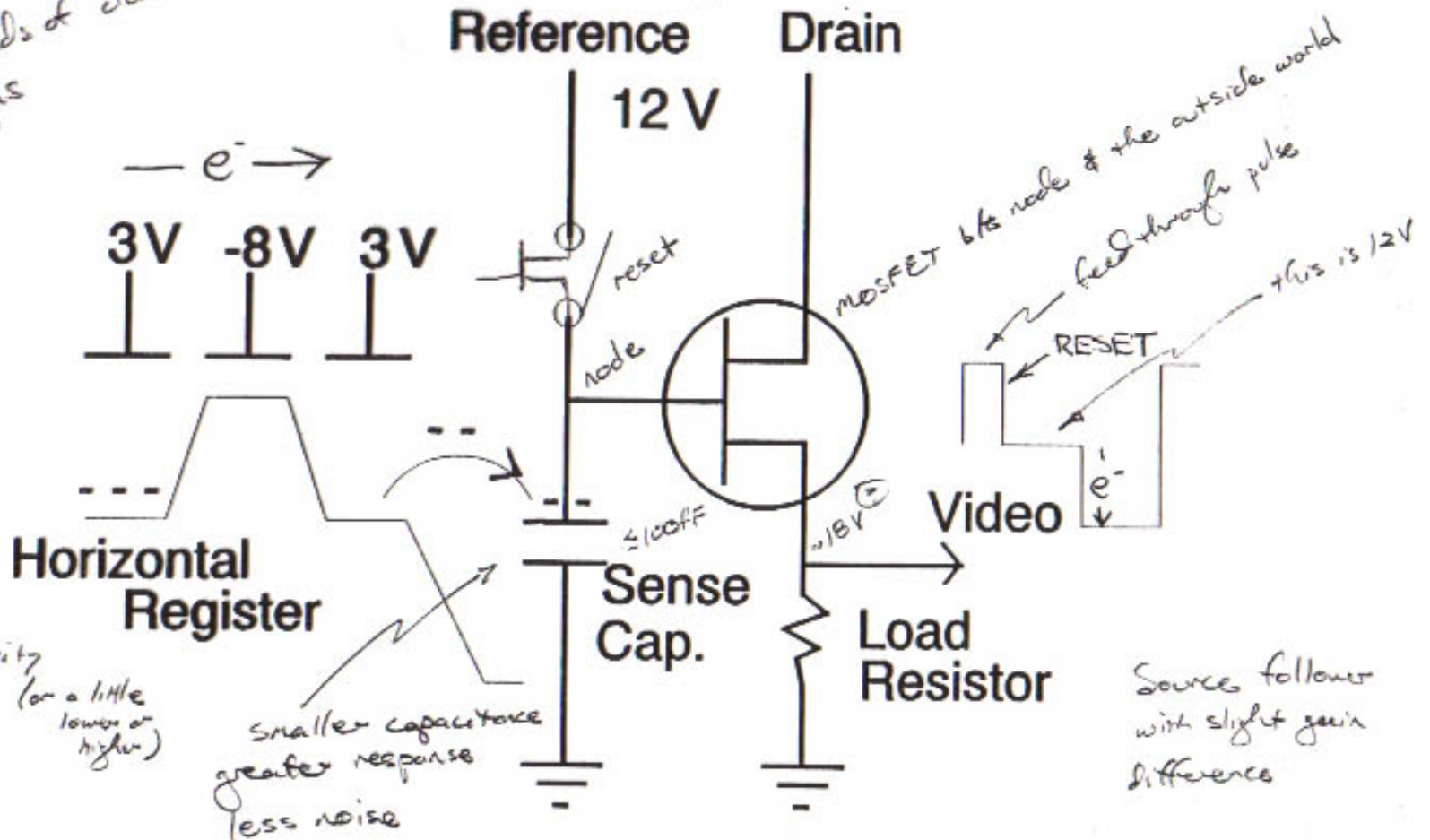

CRAF/CASSINI CCD

600X S4613

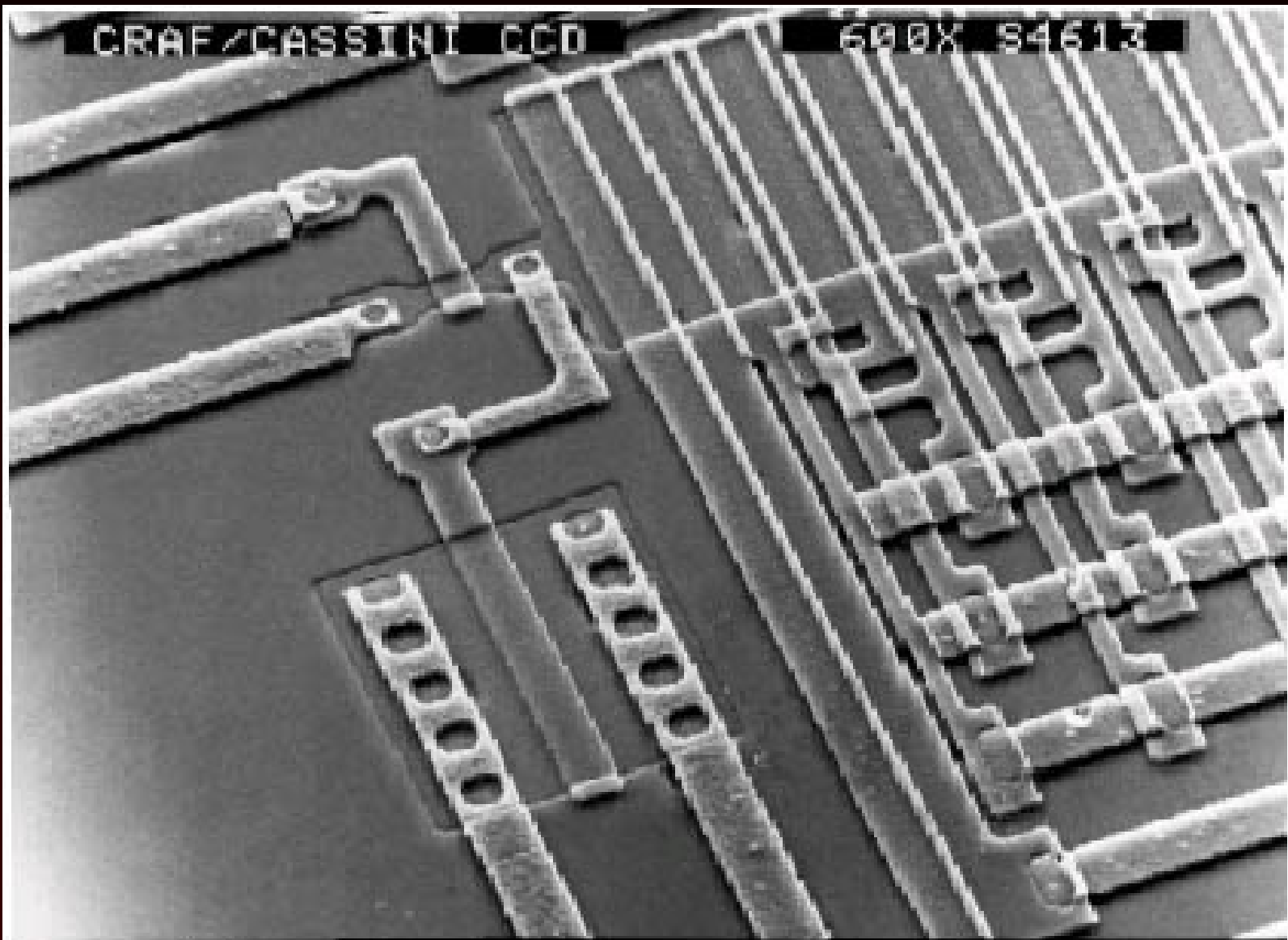

40PM

20KV

45

026

S

Amplifier Responsivity (SITe example)

$$Q = CV$$

$$V = Q / C$$

Capacitance of MOSFET = 10^{-13} F (100 fF)

Responsivity of amplifier = $1.6 \text{ V} / e^-$

More recent amplifier designs have higher responsivity, $5 - 10 \text{ V}/e^-$, which give lower noise, but less dynamic range. Research is being done on 50 xx amplifier designs which may lead to sub-electron read noise.

Infrared Detector Cross-section (InSb example)

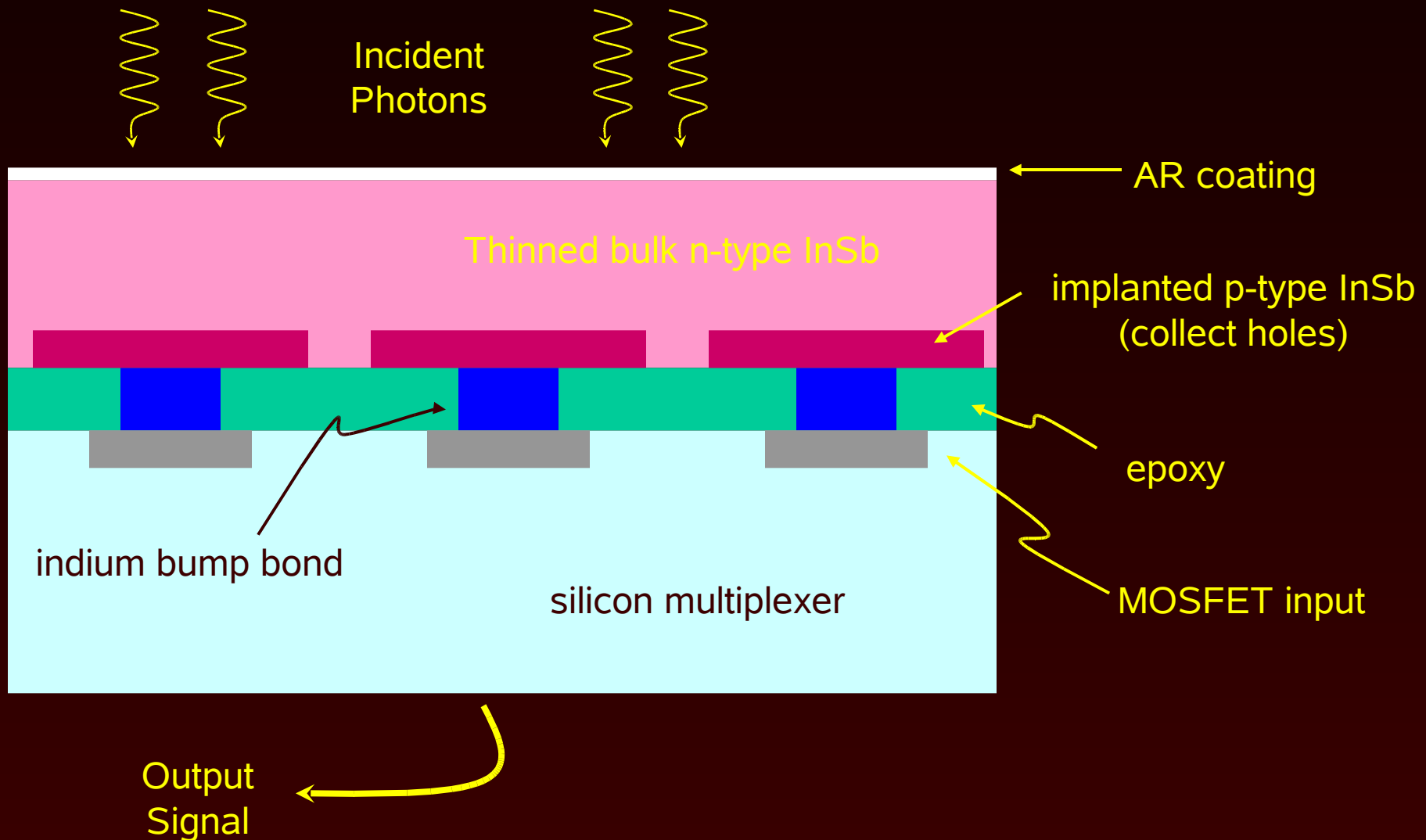

IR multiplexer pixel architecture

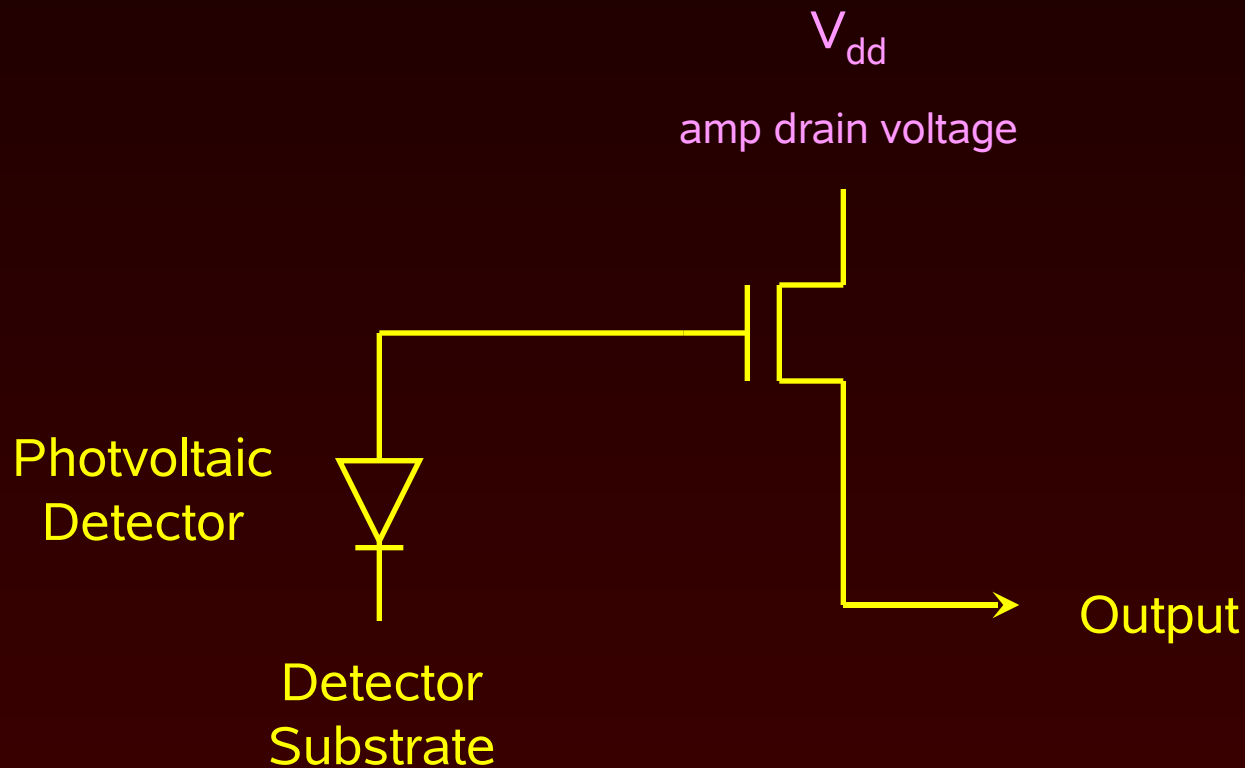

IR multiplexer pixel architecture

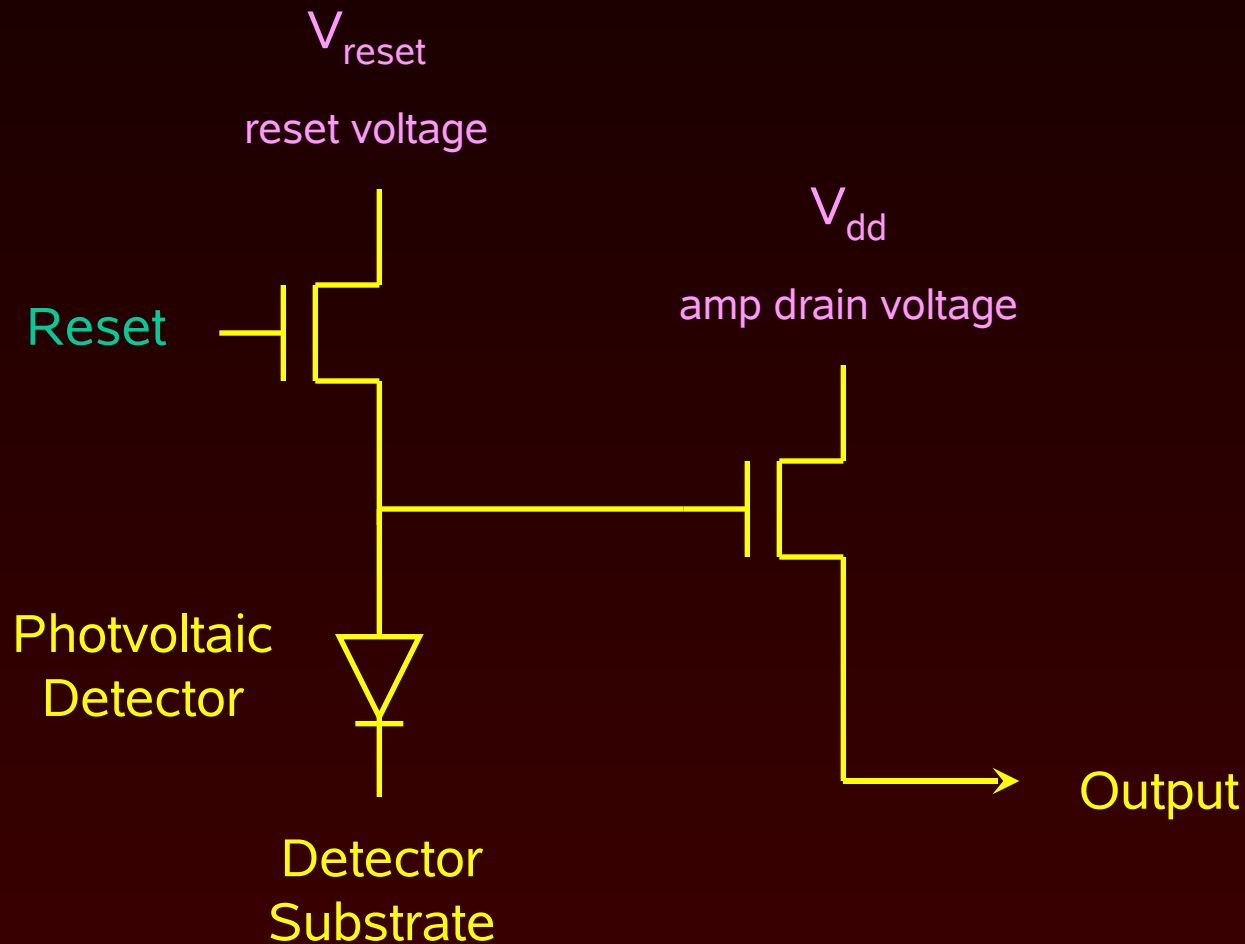

IR multiplexer pixel architecture

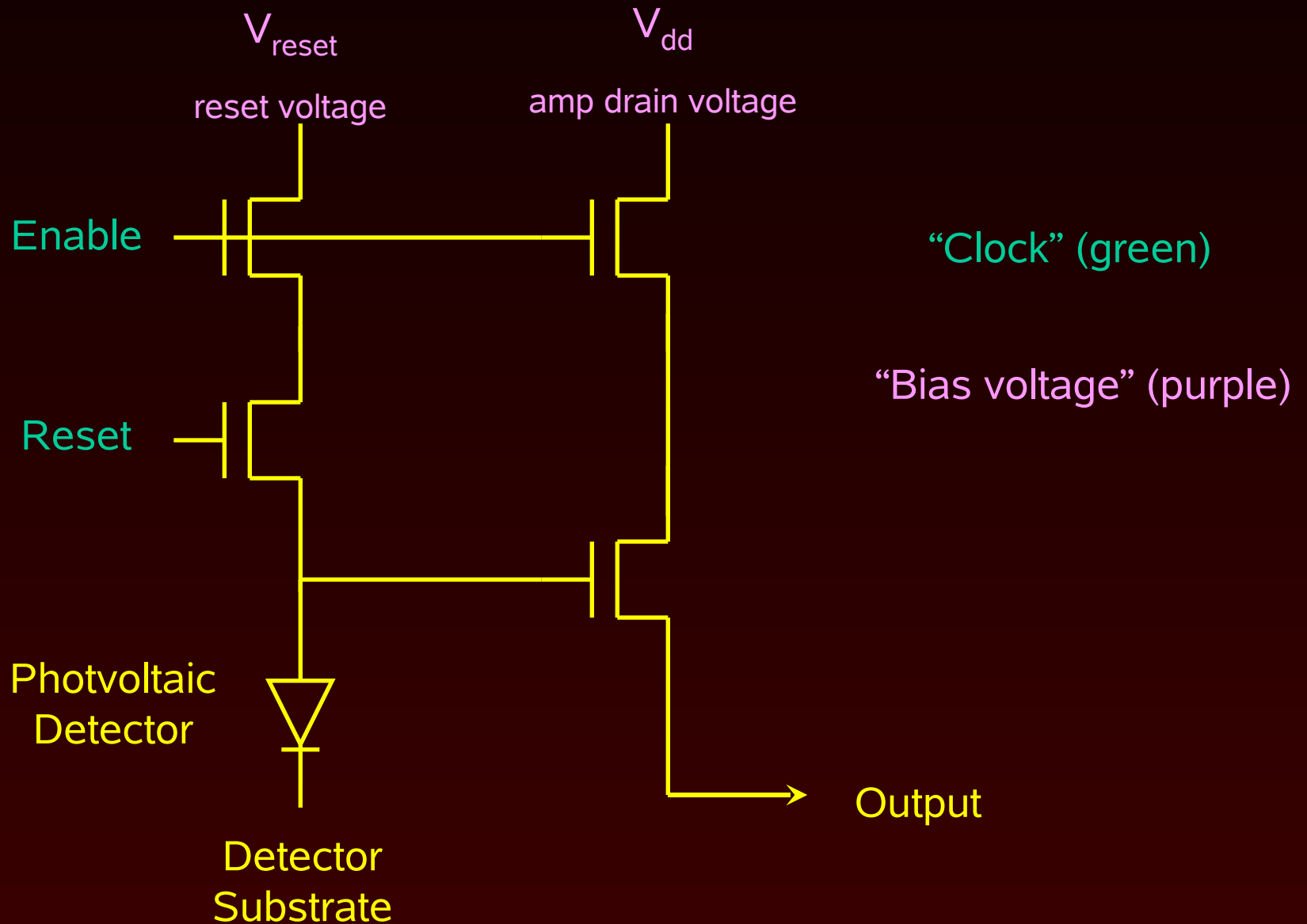

Review of Lecture 1

5 basic steps of optical/IR photon detection

1. Get light into the detector

Anti-reflection coatings - Lecture 2

2. Charge generation

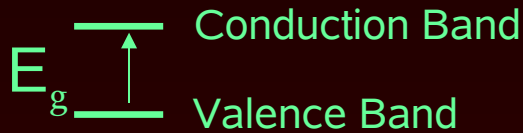

3. Charge collection

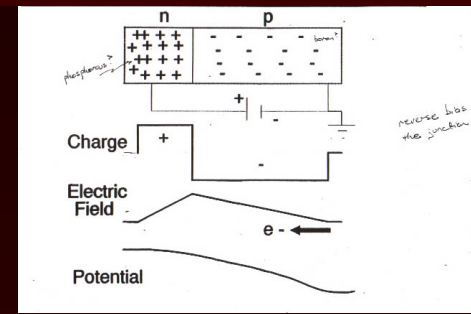

4. Charge transfer

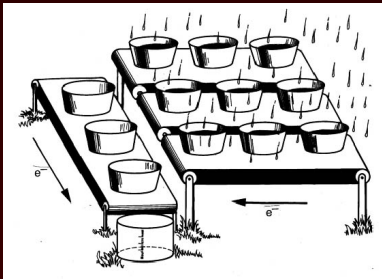

5. Charge amplification

