

Diode laser based photoacoustic gas measuring instruments intended for medical research



Anna Szabó^a, Árpád Mohácsi^a, Péter Novák^b, Daniela Aladzić^b, Kinga Turzó^c, Zoltán Rakonczay^c, Gábor Erős^d, Mihály Boros^d, Katalin Nagy^b, Gábor Szabó^a

^aDepartment of Optics and Quantum Electronics, University of Szeged, Dóm tér 9., Szeged 6720, Hungary; ^bDepartment of Oral Surgery, University of Szeged, Tisza L. krt. 64., Szeged 6720, Hungary
^cDepartment of Prosthodontics and Oral Biology, University of Szeged, Tisza L. krt. 64., Szeged 6720, Hungary; ^dSchool of Medicine Institute of Surgical Research, University of Szeged, Pécsi u. 6., 6720 Szeged, Hungary

aszabo@titan.physx.u-szeged.hu

Introduction

Analysis of breath, gases emanated from skin and oral cavity can provide information about metabolic processes and state of health. Therefore, there is a huge potential and interest in implementing novel non-invasive, real-time, easy-to-use and reliable diagnostic tools for common clinical practice. Diode laser based photoacoustic instruments measuring methane and ammonia currently operate at the research laboratories of the Faculties of Medicine and Dentistry of the University of Szeged.

Method

Photoacoustic spectroscopy measures optical absorption indirectly via the conversion of absorbed light energy into acoustic waves due to the expansion of absorbing gas sample [1]. The intensity of the generated sound wave is proportional to the concentration of the light absorbing component. Presented photoacoustic detectors consist of four main parts (Fig. 1): a near infrared diode laser; a dual-pass, temperature stabilized measuring cell with a microphone; a controlling and processing electronic unit and gas sampling system.

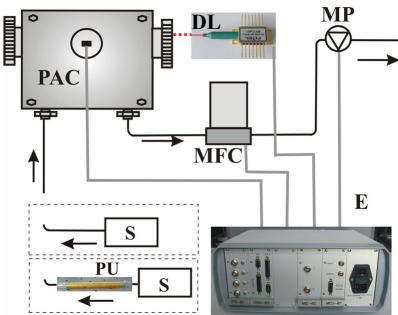

Fig. 1 Schematic view of the photoacoustic instruments. Gas samples (S) are drawn by a membrane pump (MP) into the photoacoustic cell (PAC) where the signal is generated by a diode laser (DL). Gas flow rate can be adjusted with a mass-flow controller (MFC). The electronic unit (E) provides system control and data processing. Dashed line indicates that a preconcentration unit (PU) is attached to the sampling unit (S) in case of the ammonia measuring instrument.

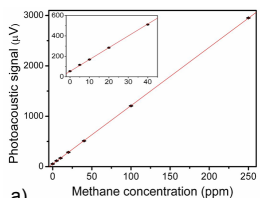
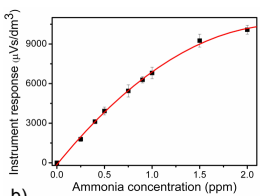

Fig. 2 Calibration curves of the instruments. Error bars show the standard deviation of data.

a) Methane detector. Solid red line shows linear regression of data ($n = 7$, $R^2 = 0.9999$).



b) Ammonia detector. Due to the saturation of the preconcentration unit the response of the instrument is not a linear function of the ammonia concentration, however, it can be well approximated by a second-order polynomial fit (solid red line).

Methane measuring instrument

Methane production of living organisms may play a role in certain physiologic processes and also may serve as an indicator of different pathologies. The methane detector measures methane emission of living animals.

Specifications:

- negligible cross-sensitivity
- gas sampling cell made of glass (180 cm³)
- 0.25 ppm minimum detectable concentration with 12 s integration time

Clinical trial:

Mice were anesthetized and placed into the glass container. After 10 minutes of methane accumulation gas from the container was drawn into the photoacoustic cell via a stainless steel tube (Fig. 3).

Methane emission measurement of an untreated mice

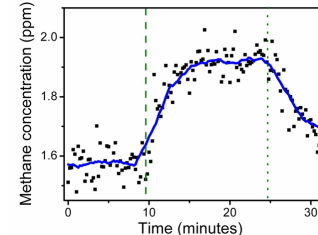

Fig. 3 Methane emission measurement of an untreated mouse. Green dashed and dotted lines indicate time when the mouse was placed into and removed from the sampling chamber, respectively. Solid blue line shows moving average over 20 points.

Mice were randomly allocated into 3 groups ($n = 8$, each group). Group 1 served as control. The animals of group 2 received antibiotic treatment (Normix) in order to eradicate intestinal bacterial flora which highly contributes to methane production. In group 3 a generalized inflammation was induced by administration of endotoxin.

Methane emission of three groups of mice

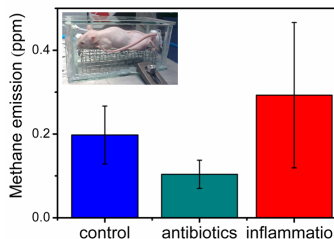

Fig. 4 Mean methane emission of three groups of mice. Error bars represent standard deviation of data ($n=8$, each group).

Elimination of intestinal bacteria led to a considerable decrease in methane emission. Inflammatory condition was accompanied by a significant increase in methane production (Fig. 4). The results suggest that methane emitted by living organisms originates not only from bacterial activity but also eukaryotic cells are able to produce this gas. Furthermore, methane emission may be an indicator of inflammatory disorders and hereby its detection may contribute to the diagnosis of such pathologies [2].

Ammonia measuring instrument

An ammonia detector has been developed for measuring ammonia from the oral cavity. Halitosis (oral malodor) affects a large part of the population. Volatile sulfur compounds (VSCs), are considered the major gases associated with halitosis. However, volatile fraction above putrefied saliva contains ammonia; therefore, it can be another component to diagnose oral health/hygiene in clinical dentistry [3].

Specifications:

- preconcentration unit [4] – 150 cm³ gas sample
- excellent selectivity
- sterilisable gas sampling glass tubes
- dynamic concentration range – 10 - 2000 ppb NH₃
- minimum detectable concentration – 10 ppb NH₃

Clinical trial:

Our preliminary study comprised 12 women with a mean age of 30 years. All volunteers were free of dental caries and periodontal disease. A measurement protocol was followed to avoid readings affected by physiological halitosis.

Thermodesorption curves of ammonia measurements from the oral cavity

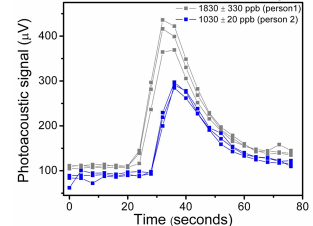

Fig. 5 Curves measured during thermodesorption, grey and blue squares indicate measurements of two volunteers. After gas sampling and baseline measurement the preconcentration unit is heated, therefore, ammonia releases. Ammonia concentrations are calculated from the area under the curves, mean concentration and standard deviation of the three consecutive measurements are indicated.

Significant correlation was found between ammonia and hydrogen sulfide concentrations (Fig. 6).

Correlation between ammonia and hydrogen-sulfide concentration

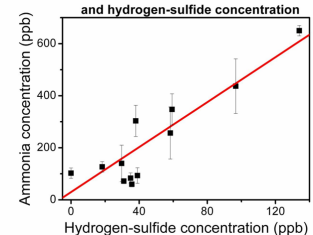

Fig. 6 Correlation between hydrogen sulfide and ammonia in halitosis measurements in a healthy women population. Solid line represents linear regression of data ($n = 12$, $R^2 = 0.821$).

Furthermore, correlation analysis was performed with the Pearson correlation coefficient and it was found to be $r = 0.906$ ($p = 0.01$). These results suggest that ammonia can be considered as another component to diagnose oral health/hygiene in clinical dentistry [3].

References

- [1] Bozókai, Z., Pogány, A. and Szabó, G., "Photoacoustic instruments for practical applications: present, potentials, and future challenges," *Appl. Spectrosc. Rev.* 46, 1-37 (2011)
- [2] Boros, M., Ghyczy, M., Erces, D., Varga, G., Tótkés, T., Kupai, K., Torday, C., Kaszaki, J., "The anti-inflammatory effects of methane," *Crit. Care Med.* 40, 1269-1278 (2012)
- [3] Amano, A., Yoshida, Y., Oho, T. and Koga, T., "Monitoring ammonia to assess halitosis," *Oral Surg. Oral Med. Oral Pathol. Oral Radiol. Endod.* 94, 692-696 (2002)
- [4] Pogány, A., Mohácsi, Á., Varga, A., Bozókai, Z., Galbács, Z., Horváth, L. and Szabó, G., "A compact ammonia detector with sub-ppb accuracy using near-infrared photoacoustic spectroscopy and preconcentration sampling," *Environ. Sci. Technol.* 43(3), 826-830 (2009)

Acknowledgement

The authors are grateful for the support of TÁMOP 4.2.1/B-09/1/KONV-2010-005, TÁMOP-4.2.2-08/1-2008-0013 and TÁMOP-4.2.2-08/1-2008-0001 projects of the Hungarian Ministry of Education.

The presentation is supported by the European Union and co-funded by the European Social Fund. Project number: TÁMOP-4.2.2/B-10/1-2010-0012

Project title: "Broadening the knowledge base and supporting the long term professional sustainability of the Research University Centre of Excellence at the University of Szeged by ensuring the rising generation of excellent scientists."

